

The Intermec logo is displayed in a bold, blue, sans-serif font. It is positioned to the left of a stylized graphic consisting of several overlapping, light blue circles and lines that resemble an atomic model or a network diagram. A small blue square icon with a white circular element is located to the right of the Intermec text, partially overlapping the graphic.

User's Guide

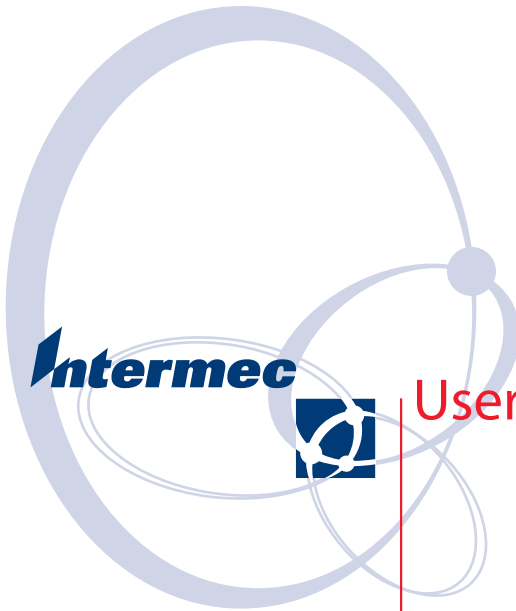

EasyCoder PF2i
Bar Code Label
Printer
(Fingerprint Version)



User's Guide

EasyCoder PF2i
Bar Code Label
Printer
(Fingerprint Version)

Intermec Technologies Corporation

Worldwide Headquarters
6001 36th Ave.W.
Everett, WA 98203
U.S.A.

www.intermec.com

The information contained herein is provided solely for the purpose of allowing customers to operate and service Intermec-manufactured equipment and is not to be released, reproduced, or used for any other purpose without written permission of Intermec Technologies Corporation.

Information and specifications contained in this document are subject to change without prior notice and do not represent a commitment on the part of Intermec Technologies Corporation.

© 2004 - 2008 by Intermec Technologies Corporation. All rights reserved.

The word Intermec, the Intermec logo, Norand, ArciTech, Beverage Routebook, CrossBar, dcBrowser, Duratherm, EasyADC, EasyCoder, EasySet, Fingerprint, INCA (under license), i-gistics, Intellitag, Intellitag Gen2, JANUS, LabelShop, MobileLAN, Picolink, Ready-to-Work, RoutePower, Sabre, ScanPlus, ShopScan, Smart Mobile Computing, SmartSystems, TE 2000, Trakker Antares, and Vista Powered are either trademarks or registered trademarks of Intermec Technologies Corporation.

There are U.S. and foreign patents as well as U.S. and foreign patents pending.

Throughout this manual, trademarked names may be used. Rather than put a trademark (™ or ®) symbol in every occurrence of a trademarked name, we state that we are using the names only in an editorial fashion, and to the benefit of the trademark owner, with no intention of infringement.

The name Centronics is wholly owned by GENICOM Corporation.

Kimdura is a registered trademark of Kimberly Clark.

Microsoft is a registered trademark of Microsoft Corporation.

TrueDoc is a registered trademark of Bitstream, Inc.

TrueType is a trademark of Apple Computer Inc.

Unicode is a trademark of Unicode Inc.

Document Change Record

This page records changes to this document. The document was originally released as Revision -00.

Version Number	Date	Description of Change
-00	5/2003	Supports original Fingerprint version (v8.00).
-01	10/2003	Revised to support Fingerprint v8.10. Information about EasyLAN Wireless interface added.
-02	2/2004	Revised to support Fingerprint v8.20 and Intermec Shell v8.1. Information on Intermec Ready-To-Work Indicator added. New setup node for LSS test added. More bar codes supported.
-001	3/2008	Revised P/N 1-960578-02 to 934-033-001. Bring into Adobe FrameMaker 8.0.

Contents

Before you Begin	xi
Safety Information	xi
Global Services and Support	xii
Warranty Information	xii
Web Support	xii
Telephone Support	xii
Service Location Support	xiii
Who Should Read This Manual	xiv
Related Documents	xiv

1 Introduction 1

Description of EasyCoder PF2i printer	2
Safety Summary	3
Product Identification	3

2 Installation 5

Front View	6
Rear View	7
Media Compartment	8
Description	8
Media Supply Roll Post	10
Media Supply Positions	10
Print Mechanism	12
Connections	13
Power	13
Computer	13
Controls and Indicators	14
Indicator Lamps	14
Display	15
Keyboard	15
Beeper	17

3 Starting Up	19
Startup Files	20
Memory Card	20
Switching On the Printer	22
4 Media Load	25
Tear-Off (Straight-Through)	26
Tear-Off With Quick-Load (Straight-Through)	30
Peel-Off (Self-Strip)	33
External Supply (Fan-Fold)	39
5 Thermal Transfer Printing	41
Ribbon Load	42
6 Setting Up the Printer	49
Description	50
Default Setup	51
Reading the Current Setup	52
Setup Parameters	52
Serial Communication	52
Baud Rate	52
Data Bits	53
Parity	53
Stop Bits	53
Flow Control	53
New Line	54
Receive Buffer	54
Transmit Buffer	55
Feed Adjust	55

Start Adjust	55
Stop Adjust	55
Recommended Feed Adjustments	56
Media	56
Media Size	56
Media Type	58
Paper Type	59
Contrast	61
Testfeed	62
Print Defines	62
Head Resistance	62
Testprint	62
Print Speed	64
LSS Test	64
LTS (Label Taken Sensor)	64
Returning to Factory Default Setup	64
7 Setup Mode	67
Entering Setup Mode at Installation	68
Navigating in Setup Mode	69
Setup Mode Overviews	71
8 Intermec Shell Startup Program	79
Introduction	80
Starting with Intermec Shell	81
Intermec Shell v8.1 Overview	85
Line Analyzer	86
9 Options	89
Introduction	90
Transfer Mechanism	91
Side Doors	91

Contents

Integral Liner Takeup Unit	91
Media Supply Hub	91
3-Inch Adapter	91
Label Taken Sensor	91
Real Time Clock	92
CompactFlash Protection Plate	92
Interface Boards	92
10 Troubleshooting	93
Intermec Ready-To-Work Indicator	94
11 Maintenance	101
Printhead Cleaning	102
External Cleaning	106
Cleaning the Media Guides	107
Printhead Replacement	109
Media Jams	113
12 Adjustments	115
Narrow Media Adjustment	116
Label Stop Sensor (LSS) Position Adjustment	118
Printhead Pressure Adjustment	121
Ribbon Break Shaft Adjustment	123
Installing the Quick-Load Guides	124
Label Taken Sensor (LTS) Adjustment	126

A	Technical Specifications	127
	Technical Data	128
B	Media Specifications	133
	Media Roll Size	134
	Media	135
	Non-Adhesive Strip	135
	Self-Adhesive Strip	136
	Self-Adhesive Labels	137
	Tickets with Gaps	138
	Tickets with Black Mark	140
C	Interfaces	143
	RS-232 Interface	144
	USB Interface	145
	Bar Code Wand Interface	146
	Optional Interfaces	147
D	Intermec Supplies	151
	Direct Thermal Media	152
	Thermal Transfer Media	152
	Transfer Ribbons	153
	Bar Code Directions	154
	Recommended Paper Type Settings (Europe)	155
	Recommended Paper Type Settings (North America)	156

Contents

Before you Begin

This section provides you with safety information, technical support information, and sources for additional product information.

Safety Information

Your safety is extremely important. Read and follow all warnings and cautions in this document before handling and operating Intermec equipment. You can be seriously injured, and equipment and data can be damaged if you do not follow the safety warnings and cautions.

This section explains how to identify and understand dangers, warnings, cautions, and notes that are in this document. You may also see icons that tell you when to follow ESD procedures.



A warning alerts you of an operating procedure, practice, condition, or statement that must be strictly observed to avoid death or serious injury to the persons working on the equipment.



A caution alerts you to an operating procedure, practice, condition, or statement that must be strictly observed to prevent equipment damage or destruction, or corruption or loss of data.



This icon appears at the beginning of any procedure in this manual that could cause you to touch components (such as printed circuit boards) that are susceptible to damage from electrostatic discharge (ESD). When you see this icon, you must follow standard ESD guidelines to avoid damaging the equipment you are servicing.



Note: Notes either provide extra information about a topic or contain special instructions for handling a particular condition or set of circumstances.

Global Services and Support

Warranty Information

To understand the warranty for your Intermec product, visit the Intermec web site at www.intermec.com and click **Support > Returns and Repairs > Warranty**.

Disclaimer of warranties: The sample code included in this document is presented for reference only. The code does not necessarily represent complete, tested programs. The code is provided “as is with all faults.” All warranties are expressly disclaimed, including the implied warranties of merchantability and fitness for a particular purpose.

Web Support

Visit the Intermec web site at www.intermec.com to download our current manuals (in PDF). To order printed versions of the Intermec manuals, contact your local Intermec representative or distributor.

Visit the Intermec technical knowledge base (Knowledge Central) at www.intermec.com and click **Support > Knowledge Central** to review technical information or to request technical support for your Intermec product.

Telephone Support

These services are available from Intermec.

Services	Description	In the USA and Canada call 1-800-755-5505 and choose this option
Order Intermec products	<ul style="list-style-type: none">Place an order.Ask about an existing order.	1 and then choose 2
Order Intermec media	Order printer labels and ribbons.	1 and then choose 1
Order spare parts	Order spare parts.	1 or 2 and then choose 4
Technical Support	Talk to technical support about your Intermec product.	2 and then choose 2

Services	Description	In the USA and Canada call 1-800-755-5505 and choose this option
Service	<ul style="list-style-type: none">• Get a return authorization number for authorized service center repair.• Request an on-site repair technician.	2 and then choose 1
Service contracts	<ul style="list-style-type: none">• Ask about an existing contract.• Renew a contract.• Inquire about repair billing or other service invoicing questions.	1 or 2 and then choose 3

Outside the U.S.A. and Canada, contact your local Intermec representative. To search for your local representative, from the Intermec web site, click **About Us > Contact Us**.

Service Location Support

For the most current listing of service locations, click **Support > Returns and Repairs > Repair Locations**.

For technical support in South Korea, use the after service locations listed below:

AWOO Systems

102-1304 SK Ventium
522 Dangjung-dong
Gunpo-si, Gyeonggi-do Korea, South 435-776
Contact: Mr. Sinbum Kang
Telephone: +82-31-436-1191
E-mail: mjyun@awoo.co.kr

IN Information System PTD LTD

6th Floor
Daegu Venture Center Bldg 95
Shinchun 3 Dong
Donggu, Daegu City, Korea
E-mail: jmyou@idif.co.kr or korlim@gw.idif.co.kr

Who Should Read This Manual

This manual is for the person who is responsible for installing, configuring, and maintaining the EasyCoder PF2i printer.

This manual provides you with information about the features of the EasyCoder PF2i printer, and how to install, configure, operate, maintain, and troubleshoot it.

Before you work with the EasyCoder PF2i printer, you should be familiar with your network and general networking terms, such as IP address.

Related Documents

The Intermec web site at www.intermec.com contains our documents (as PDF files) that you can download for free.

To download documents

- 1** Visit the Intermec web site at www.intermec.com.
- 2** Click **Support > Manuals**.
- 3** In the **Select a Product** field, choose the product whose documentation you want to download.

To order printed versions of the Intermec manuals, contact your local Intermec representative or distributor.



1 Introduction

This chapter introduces the EasyCoder PF2i printer. The chapter covers the following topics:

- Description of EasyCoder PF2i printer
- Safety Summary
- Product Identification

Description of EasyCoder PF2i printer

The EasyCoder PF2i printer is a sturdy medium-duty direct thermal printer with a printhead resolution of 8 dots per mm (203.2 dots per inch) and a maximum print width of 56 mm (2.2 inches). Optionally, it can be provided with a thermal transfer mechanism. The EasyCoder PF2i printer offers a large number of useful features, such as:

- Flash memory SIMMs for firmware, fonts, bar codes, and application programs
- Built-in CompactFlash memory card adapter
- Built-in RS-232 interface and USB interfaces
- Provision for extra interface boards including wired and wireless EasyLAN connections
- Keyboard and display with backlight for improved user interface

A large number of factory-installed or field-installable options are available, so the printer can be configured for a wide range of applications. See [“Options” on page 89](#) and [“Technical Specifications” on page 127](#) for more information.

The EasyCoder PF2i printer supports the unique and flexible Intermec Fingerprint v8.20 programming language, which allows the user or third-party developer to create custom-made application programs and label formats in a BASIC-like environment. A version of EasyCoder PF2i printer, that supports Intermec Programming Language (IPL), is described in *EasyCoder PF2i Bar Code Label Printer User’s Guide (IPL Version)* (P/N 934-031-xxx).

EasyCoder PF2i is also designed to work with the Intermec Direct Protocol programming language, the Intermec InterDriver and Intermec Labelshop. The InterDriver allows you to print labels from standard MS Windows applications, for example Microsoft Office.

Intermec LabelShop is a series of label-design programs that work under various versions of MS Windows.

The EasyCoder PF2i supports 15 scalable Unicode TrueType and TrueDoc fonts as standard. Additional fonts can be downloaded into the printer's Flash memory, or be plugged in using a CompactFlash card. The Unicode standard allows the use of special characters for various languages including non-Latin fonts, such as Arabic, Cyrillic, Chinese, Japanese, Korean, Hebrew, and similar.

Safety Summary

Intermec assumes no responsibility regarding the CE Directive if the printer is handled, modified, or installed in any way other than that described in Intermec's manuals.

- Read this manual carefully before connecting the printer.
- Moving parts are exposed when the side door is open, so ensure that the door is closed before you operate the printer.
- Do not open the front/left-hand cover. Dangerous voltage!
- Do not remove the bottom plate. Dangerous voltage!
- Do not put your fingers inside the print mechanism when the power is on.
- Place the printer on an even surface which can support its weight of approximately 5.5 kg (12 lbs.) plus supplies.
- Do not spray the printer with water. If you are using a hose to clean the premises in an industrial environment, remove the printer or protect it carefully from spray and moisture.
- Carefully read the warning text on the envelope before using a cleaning card.

Product Identification

The machine label is attached to the printer's rear plate and contains information on type, model, and serial number as well as AC voltage. It also contains various signs of approval.



2 Installation

This chapter explains how to unpack and install the EasyCoder PF2i printer and also describes the printer's various parts in detail. It covers the following topics:

- Front View
- Rear View
- Media Compartment
- Print Mechanism
- Connections
- Controls and Indicators

Front View

At the front of the printer are the display window, the indicator lamps, and the keyboard. These features allow the operator to control and set up the printer manually.

The printed labels, tickets, or tags are presented at the front of the print mechanism.

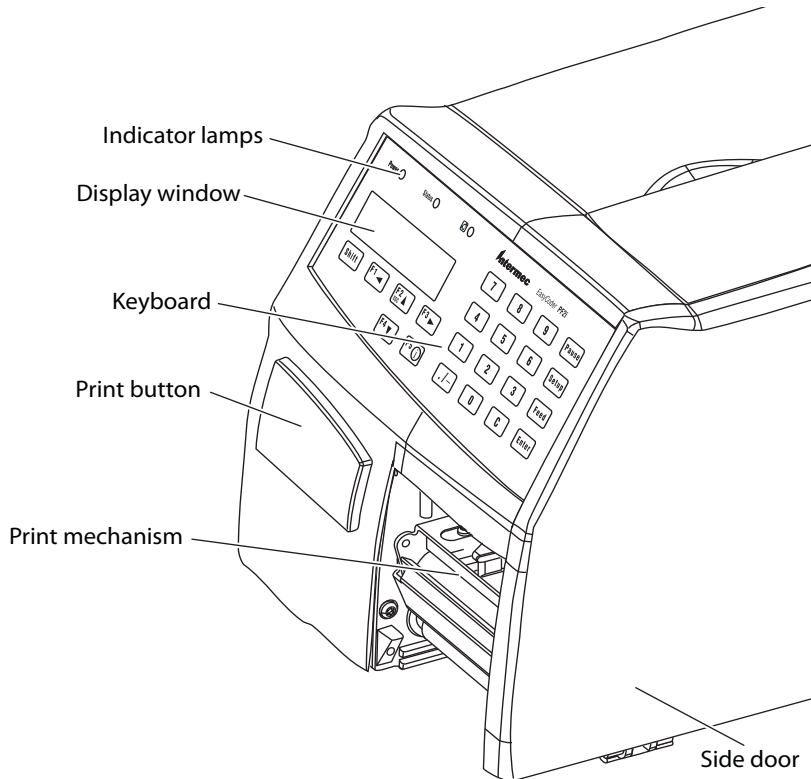

Rear View

The rear plate contains the On/Off switch, the AC power cord socket, and various interface connectors and slots.

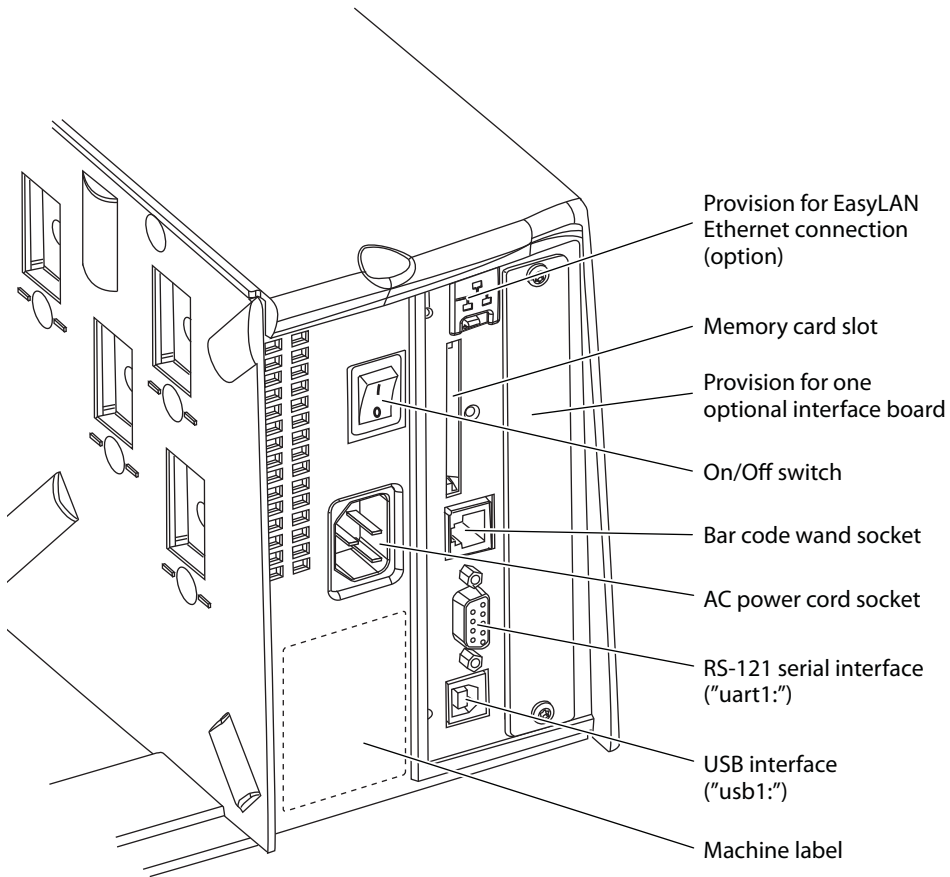

Media Compartment

Description

The media compartment is either covered by a long side door that completely encloses the print mechanism and media compartment, or a short side door that only covers the print mechanism and gives easy access to the media stock. The door is held by a magnetic lock. It can be opened 180° to provide full access to the media compartment.

The media supply can be from a supply post, or from an external supply of fan folds behind the printer. There is also an optional rotating media supply hub.

Also see “[Media Supply Hub](#)” on page 91.

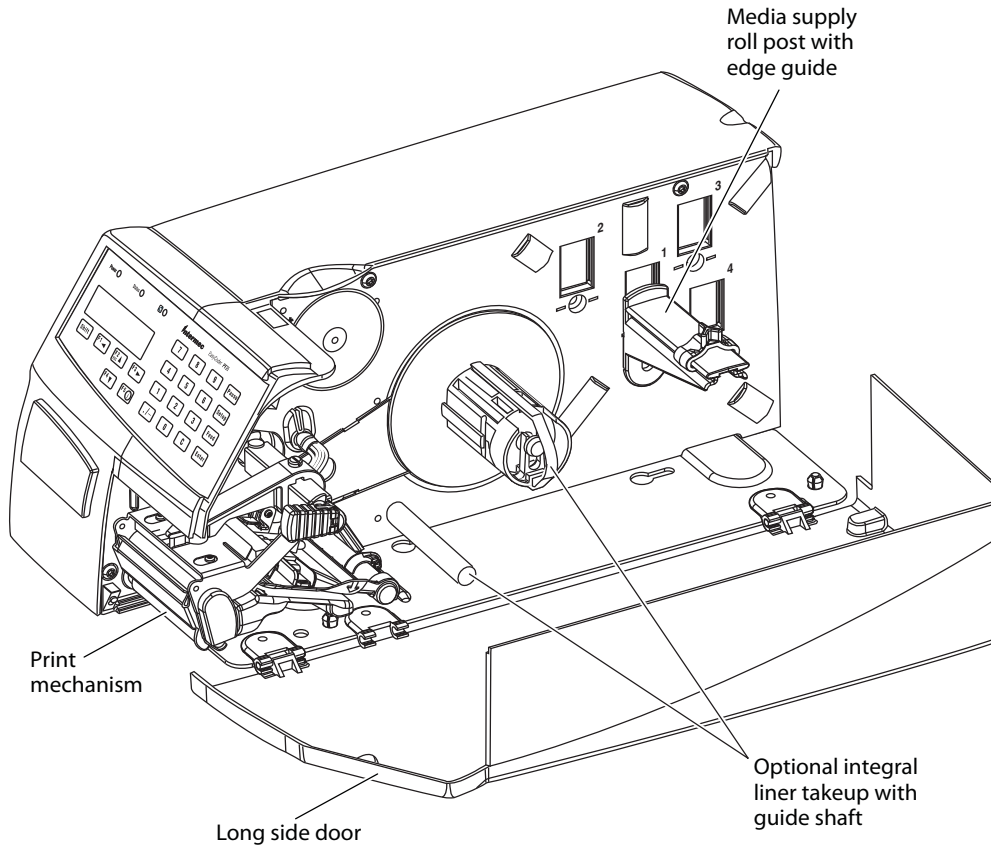

The EasyCoder PF2i printer uses a media supply roll post that can be fitted in three different positions inside the media compartment. The position depends on the type of side door (long or short) and whether or not the printer is fitted with an integral liner takeup. Alternatively, an external media supply (for example a box of fan-folded tickets) behind the printer can be used. A rotating media supply hub is also available as an option, see “[Media Supply Hub](#)” on page 91.

Media Supply Roll Post

The media supply roll post fits both 38-40 mm (1.5 inches) and 76 mm (3.0 inches) cores since it can be moved vertically in the slot in the center section. The bottom position is intended for small cores and the top position is for large cores. The post is locked by a straight-slot screw and has a moveable edge guide to fit various media widths.

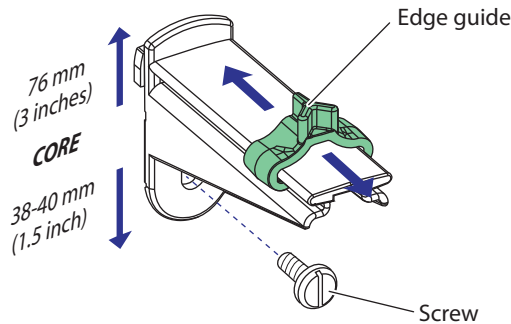

Make sure to adjust the position of the post according to the size of the media roll core. When the post is fitted in the top position, the head of the screw will interfere with small (38 mm/1.5 inches) cores, causing media misalignment.

To move the post to a different slot; remove the screw, twist the post a quarter of a turn, and pull it out.

To fit the post; rotate it a quarter of a turn, insert it into the appropriate slot in the center section (see next page), and twist back so the lips engage the cutouts in the sides of the slot. Move it up (large core) or down (small core) as far as it goes and secure it with the screw.

Media Supply Positions

There are four sets of threaded holes and slots in the printer's center section for the media supply roll post or rotating hub (optional). These slots allow the largest possible roll size to fit, given the limitations of any liner takeup and/or the full enclosure provided by the long side door. The positions are indicated by numbers engraved in the center section.

- Position 1 is used when the media compartment is fully enclosed by a long side door, regardless of the existence of any integral liner takeup unit. Maximum roll size is 152 mm (6 inches).
- Position 2 is used when the printer has a short side door that only encloses the print mechanism, but does not have an integral liner takeup unit. Maximum roll size is 203 mm (8.00 inches).
- Position 3 is used when the printer has a short side door and an integral liner takeup unit. Maximum roll size is 213 mm (8.38 inches).
- Position 4 is not used.

The printer can also use an external media supply located behind the printer.

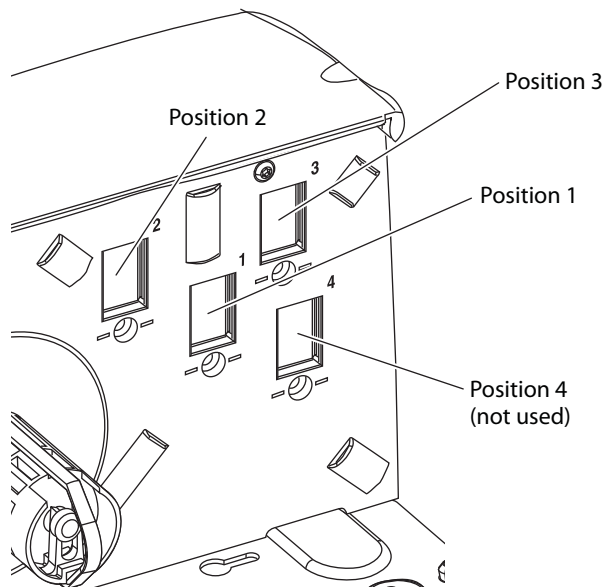

Print Mechanism

The print mechanism features a high-performance 8 dot/mm (203.2 dots/inch) thermal printhead with quick-mount fittings to facilitate replacement. Refer to [“Thermal Transfer Printing” on page 41](#) and [“Options” on page 89](#) for illustrations of the thermal transfer mechanism, which is partly integrated with the print mechanism.

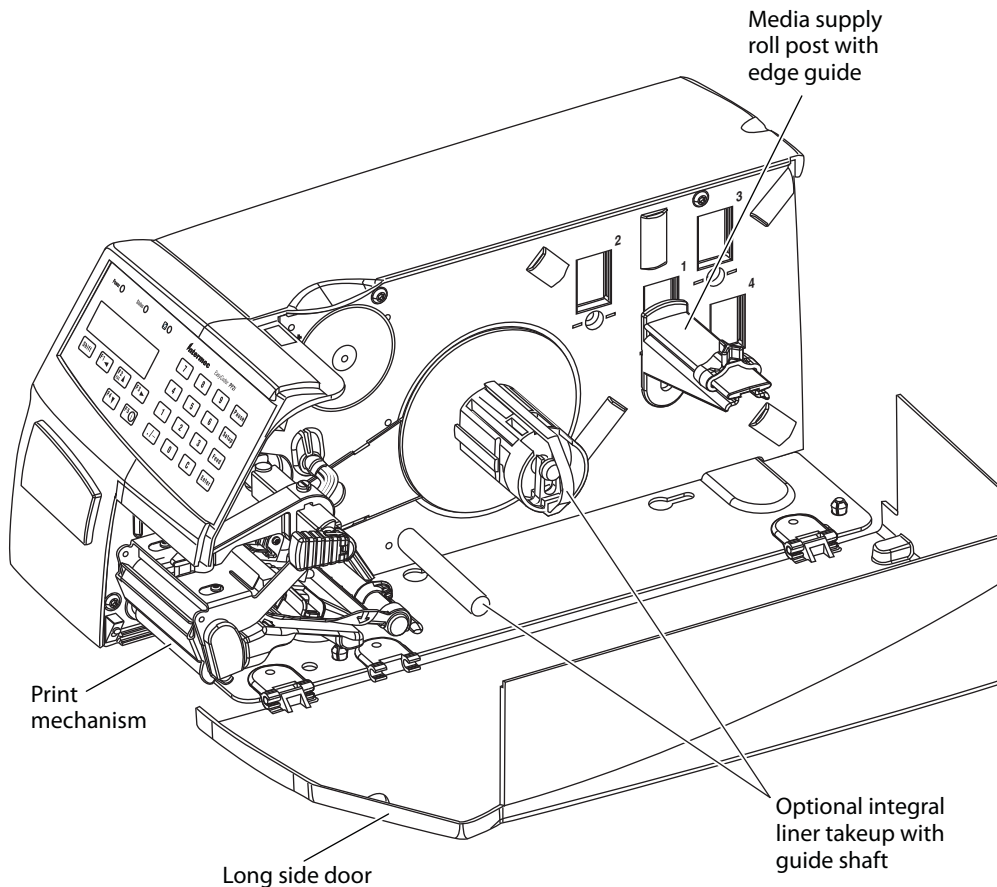

Connections

Power

To connect power to the printer:

- 1 Place the printer on a level surface, near an AC outlet. You should be able to easily access the printer to load media and to remove the printout.
- 2 Check that the printer is switched off.
- 3 Connect the power cord from the socket on the rear plate to an electrical outlet (90 to 265 VAC).

Computer

The EasyCoder PF2i printer is fitted with one 9-pin D-style subminiature (DB9) socket for the RS-232 serial interface port (see [“Interfaces” on page 143](#)).

RS-232 Serial Interface (“uart1:”)

Use the serial interface with Intermec LabelShop or the Intermec InterDriver. Also use it with the Intermec Direct Protocol or the Intermec Fingerprint programming language because you can receive error messages from your printer. Before you can use the serial interface, you may need to set up the communication parameters, such as baud rate, parity, etc. as described in [“Setting Up the Printer” on page 49](#).

USB Interface (“usb1:”)

Use the USB interface with an USB-compatible version of the Intermec InterDriver for printing. The USB interface is not suitable for programming because the host cannot receive error messages from your printer.

Optional Interface and Network Boards (“uart2:”, “uart2:”, “centronics:”, or “net1:”)

Several types are available (see [“Options” on page 89](#)). Refer to [“Setting Up the Printer” on page 49](#), [“Setup Mode” on page 67](#), and [“Interfaces” on page 143](#) for connection and setup instructions.

The printer can be set to scan all communication ports. When it detects incoming data on a port, the printer automatically switches to use that port for both input and output. This facility (“auto”) can be selected in Intermecc Shell (see “[Intermecc Shell Startup Program](#)” on page 79) or using the Intermecc Fingerprint instruction SETSTDIO, see *Intermecc Fingerprint v8.xx, Command Reference Manual* (P/N 937-005-xxx). Use the F5/i key to get information on the active communication channels.

Switch off both PC and printer before connecting them together.

Controls and Indicators

The EasyCoder PF2i printer has several ways of communicating directly with its operator: three colored indicator lamps, a display window, a membrane-switch keyboard with 22 keys, a big programmable **Print** button on the printer’s front, and a beeper.

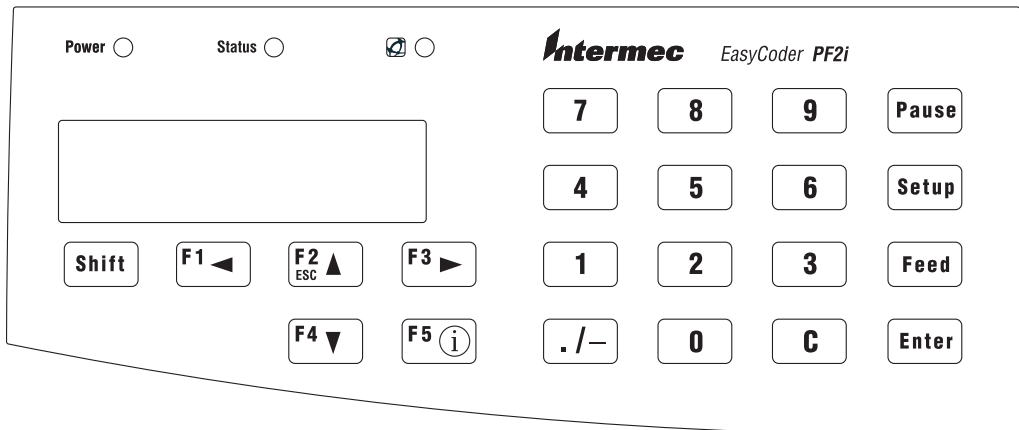

Indicator Lamps

The indicators are colored LEDs (Light Emitting Diodes) and are used for the following purposes:

Power 

Power (solid green) indicates that the power is on.

Status 

Status (solid green) indicates that the printer is ready for use.



Status (flashing green) indicates that the printer is communicating.



Status (solid red) indicates an error condition (see [“Intermec Ready-To-Work Indicator” on page 94](#)).



Intermec Ready-To-Work Indicator (blue; on, blink, or off). Represented by a blue light on Intermec handheld computers, access points, and printers, the Intermec Ready-To-Work Indicator is part of an exclusive monitoring system from Intermec. The Intermec Ready-To-Work Indicator helps users quickly determine the readiness of the Intermec device individually and as part of a solution. The Intermec Ready-To-Work Indicator has three different states: On, Blinking, and Off. When the Indicator is off, the device is not ready to operate individually or as part of a solution. When the Indicator is blinking, the device may be initializing, waiting for external resources, or in need of user attention. And when the Indicator is On, the device is ready for use as part of a solution. Also see [“Troubleshooting” on page 93](#).











Display

The display window contains an LCD (Liquid Crystal Display) with background illumination and two lines of text, each with 16 characters. It guides the operator through the setup and indicates possible errors during printing. The Intermec Fingerprint programming language and the Intermec Direct Protocol allow custom-made messages to be composed and displayed according to the requirements of the application.

Keyboard

The keyboard is of the membrane-switch type and has 22 keys. The keyboard is supplemented by a large **Print** button on the printer's front. Some keys have hard-coded functions in the startup and setup modes:

Keyboard Buttons

Button	Function
Print button	Feed/Pause a print job. Repeat last printed label.
	Toggle between pause and printing when executing a print job.
 + 	Interrupt a running Fingerprint program.
	Enter the Setup Mode (see “Setup Mode” on page 67).
	Feed out a blank label or the equivalent.
 + 	Perform a Testfeed (feed a blank label, adjust the media feed).
	Display error messages, IRI status, and communication channel information.
 	Scroll between various types of information after pressing the F5/i key. Possible error messages and information on active communication channels are shown in a loop.

Keyboard Color Code

Keyboard Color	Code
Yellow	Operation of the printer (operator level)
Green	Setup or service (site or service technician level)
White	Data input to printer (operator or technician level)

In application programs created using the Intermec Fingerprint programming language, the keys can be assigned to various functions or be disabled individually. Since one key is assigned as shift key, up to 44 different key combinations are possible. An audible signal, which can be turned off if so desired, acknowledges that a key has been pressed.

Beeper

The beeper notifies the operator when an error has occurred and acknowledges that a key has been pressed. The Intermec Fingerprint programming language allows the key acknowledge signal to be turned off. The frequency and duration of signals can be specified. Thus it is possible to create different signals for different conditions or even to make the printer play simple melodies!



3 Starting Up

This chapter explains how to start up the printer after installation or after the printer has been switched off. It covers the following topics:

- Startup Files
- Memory Cards
- Switching on the Printer
- Display Messages at Startup

Startup Files

When the printer is switched on, its behavior depends on the existence of a startup file (autoexec.bat) in its memory. There are two cases:

- The printer is only fitted with the Intermecc Shell file-managing program, which allows the operator to choose between a variety of applications and functions.
- In addition to Intermecc Shell, the printer is also fitted with a custom made application program that is design to perform a specific task, for example to print tickets, baggage tags, or product labels for a certain company. Such a program may be initiated by a startup file (autoexec.bat) stored in the printer's permanent memory or in a memory card.

There can be one startup file stored in each of three different parts of the printer's memory. If there are startup files stored in more than one part, only one will be used with the following priority:

- 1 An autoexec.bat file stored in a memory card, provided the card was inserted in the printer before the power was switched on.
- 2 An autoexec.bat file stored in the read/write part of the printer's permanent memory (device "/c").
- 3 The pup.bat file (Intermecc Shell) in the read-only part of the printer's permanent memory (device "/rom").



Note: If you insert a CompactFlash memory card that contains a startup file before you switch on the printer, this startup file will be used instead of Intermecc Shell.

Memory Card

If you want to use a memory card, you must insert it into the slot in the printer's rear plate before you switch on the power. The memory card must be a CompactFlash card (8MB-1GB). CompactFlash cards marked "CF+" will not work. You can use the CompactFlash card to expand the printer's storage memory ("card1:"). There are also three types of pre-programmed CompactFlash cards:

- Font Cards provide additional fonts that can be used as long as the card remains inserted in the printer.
- Font Install Cards permanently install additional fonts in the printer, which can be used even after the card has been removed.
- Firmware Cards automatically replace the printer's firmware, usually with an updated version.

CompactFlash cards are widely used for consumer's computer products like digital cameras. You can get a certain protection from theft by installing an optional plate that covers an inserted CompactFlash card.

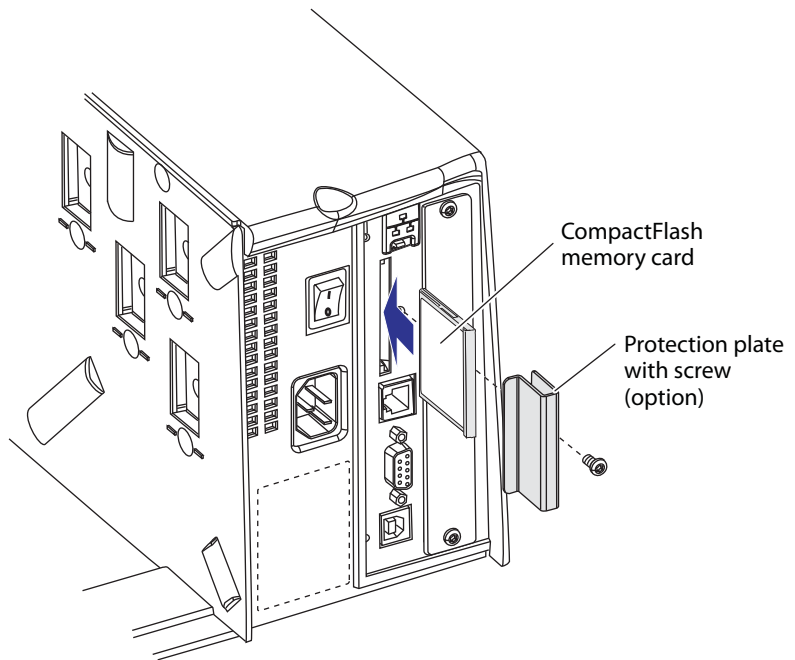

Note: Always switch off the power before inserting or removing a memory card! The card will only fit in one way. A memory card is only detected if it is inserted before the printer is started.

Switching On the Printer

Before switching on the printer, make the necessary connections, insert any memory card you want to use, and check that the printhead is engaged.

Switch on the power using the On/Off switch on the rear plate. The “Power” control lamp on the front panel lights up when the power is on. Wait for a few moments, while the printer loads the program and runs some self-diagnostic tests:

```
Starting  
■■■■■■■
```

After a short time, the printer is initialized. The progress of the initialization is indicated by an increasing number of colons on the lower line in the display:

```
Initializing  
:::
```

The type of startup file running in the printer is indicated by the message shown in the display window immediately after initialization.

A. Intermec Shell Startup Program

```
ENTER=SHELL  
5 sec. v.8.1  
4 sec. v.8.1  
3 sec. v.8.1  
2 sec. v.8.1  
1 sec. v.8.1
```

Refer to [“Intermec Shell Startup Program” on page 79](#) for more information on Intermec Shell. The digits in the lower right corner of the display indicate the version of Intermec Shell.

B. Custom-Made Application Program

Any other display messages than those illustrated above indicates that the printer is running some custom-made, non-standard application program, or that some error has occurred.



4 Media Load

This chapter explains how to load the printer with media, that is labels, tickets, tag, or strips, for the following modes of operation:

- Tear-Off (Straight-Through)
- Tear-Off with Quick-Load (Straight-Through)
- Peel-Off (Self-Strip)
- External supply (Fan-Folds)

Tear-Off (Straight-Through)

The EasyCoder PF2i printer can print on labels, tickets, tags, and continuous stock in various forms. This section describes the case when the media is torn off manually against the printer's tear bar. This method is also known as “straight-through printing.”

Use the **Feed** key when loading the same type of media. When switching to a new type of media, or if the printer does not feed out the media properly, simultaneously press the **Shift** and **Feed** keys to perform a “testfeed.”

Tear-off can be used for:

- Non-adhesive continuous stock
- Self-adhesive continuous stock with liner
- Self-adhesive labels with liner
- Tickets with gaps, with or without perforations
- Tickets with black marks, with or without perforations

An optional label taken sensor can hold the printing of the next copy in the batch until the present copy has been removed, see [“Label Taken Sensor” on page 91](#).

To load tear-off media

- 1 Open the side door.

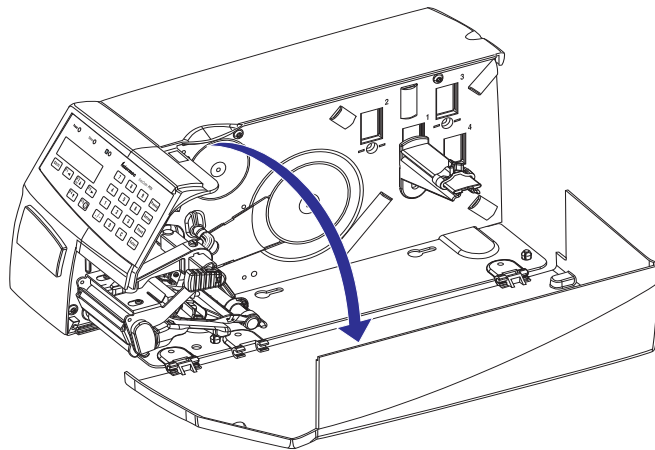

- 2 Turn the printhead lift lever clockwise to raise the printhead.

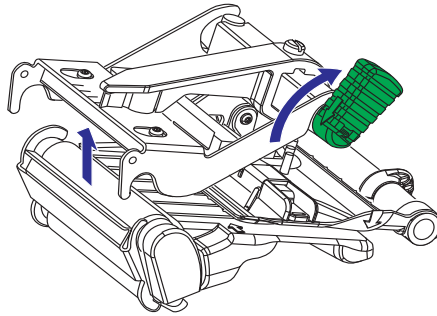

- 3 Remove any empty core from the media supply roll post.

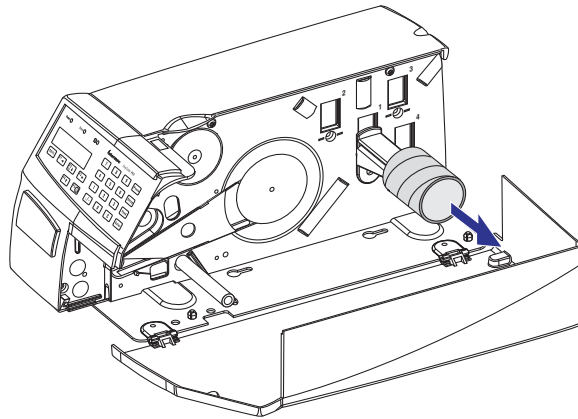

- 4 Fit new roll of media on the supply post and adjust the edge guide, so the roll becomes flush with the center section.

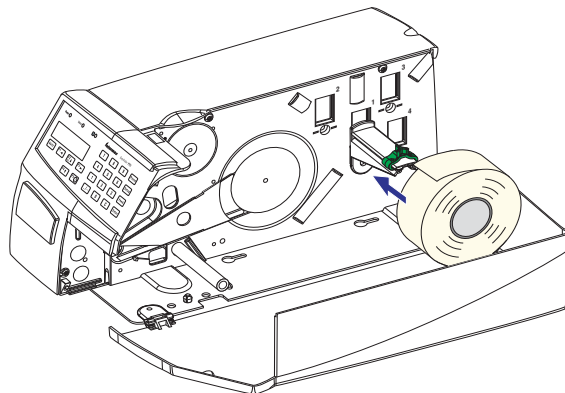

- 5 Route the media through the print mechanism. Then push it inwards as far as it will go.

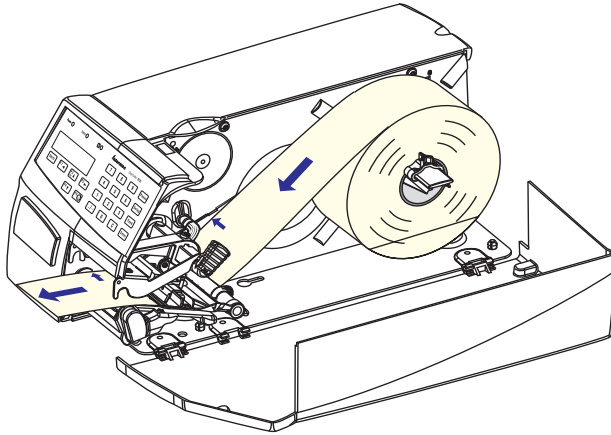

- 6 This diagram shows the media path.

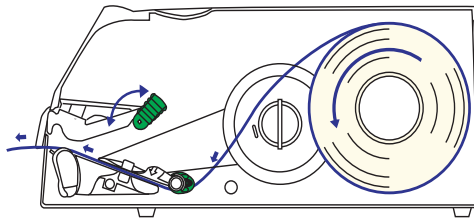

- 7 Turn the printhead lift lever counterclockwise to engage the printhead.

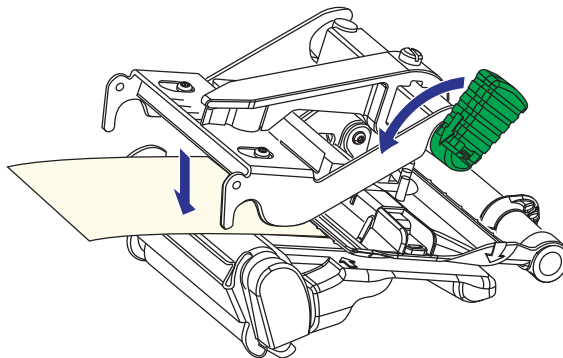

- 8 Adjust the position of the green edge guide, so the media is guided with a minimum of play.

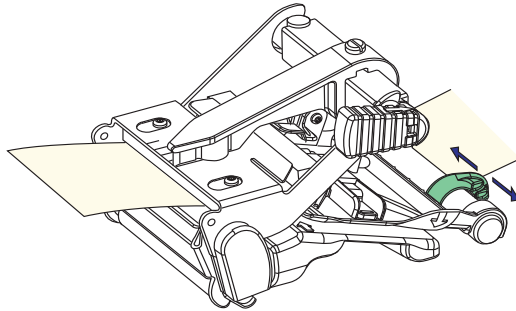

- 9 Close the side door.

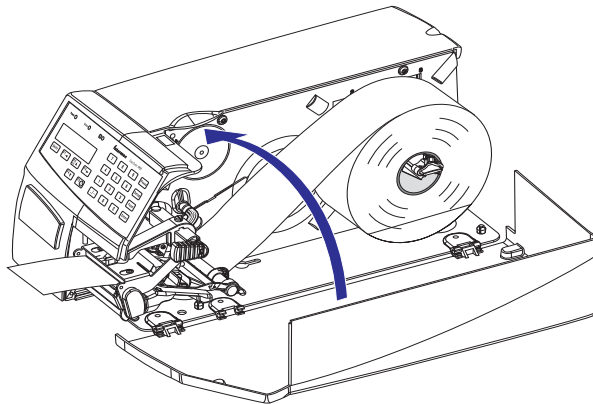

- 10 Press the Feed button to advance the media and adjust the media feed.

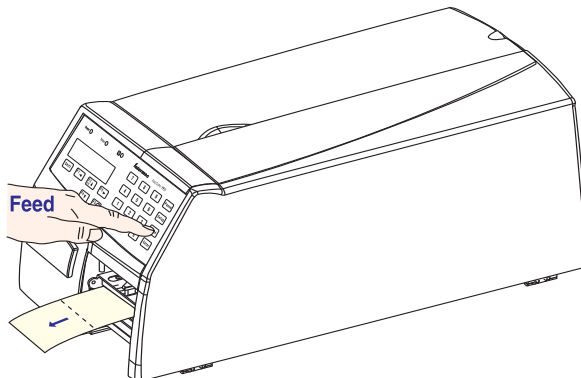

- 11 To tear off the media, grab the outer edge and pull downwards.

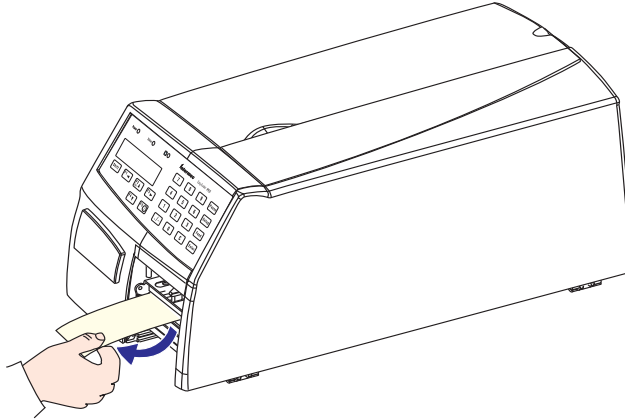

Tear-Off With Quick-Load (Straight-Through)

In addition to the media load procedure for tear-off (straight-through) operation described earlier in this chapter, the EasyCoder PF2i printer can optionally be fitted with a set of quick-load guides that makes media load much easier and quicker, especially if the printer has a short side door. See [“Adjustments” on page 115](#) for installation instructions.

Quick-load cannot be combined with peel-off (self-strip) operation.

Use the **Feed** key when loading the same type of media. When switching to a new type of media, or if the printer does not feed out the media properly, simultaneously press the **Shift** and **Feed** keys to perform a “testfeed.”

An optional label taken sensor can hold the printing of the next copy in the batch until the present copy has been removed, see [“Label Taken Sensor” on page 91](#).



Note: Full automatic loading, without the operator having to press any key, requires a special set of Intermec Fingerprint instructions in the application program.

To load tear-off media with Quick-Load

- 1 Remove any empty core from the media supply roll post.

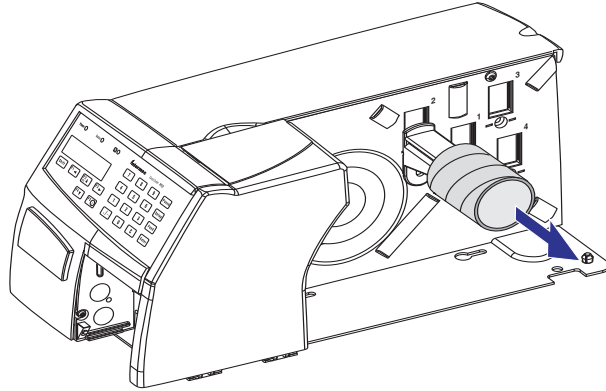

- 2 Fit a new roll of media on the supply post and adjust the edge guide, so the roll becomes flush with the center section.

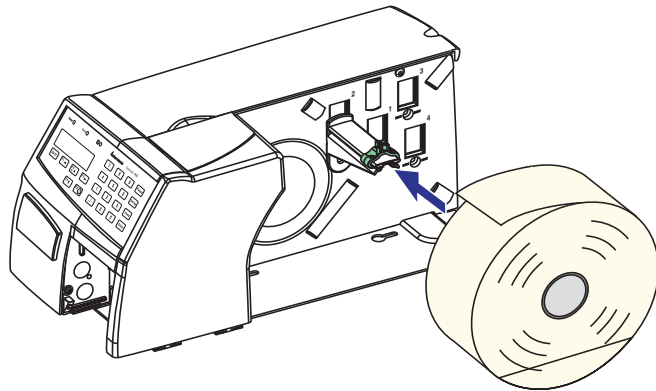

- 3 If necessary, adjust the outer quick-load guide to fit the width of the media.

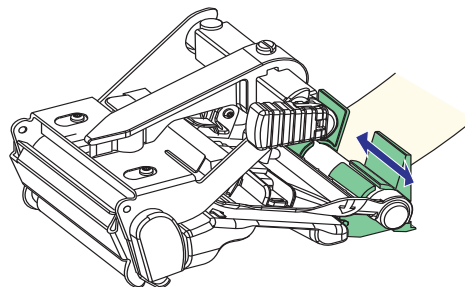

- 4 Insert the media between the guides and feed it forward until the media reaches the platen roller and cannot be inserted any further.

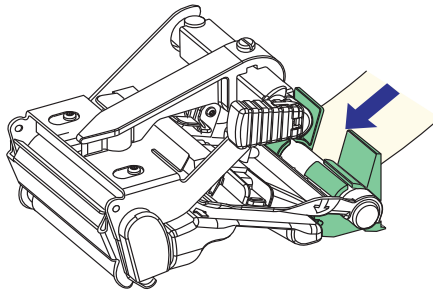

- 5 Keep pushing the media forward while pressing the Feed button.

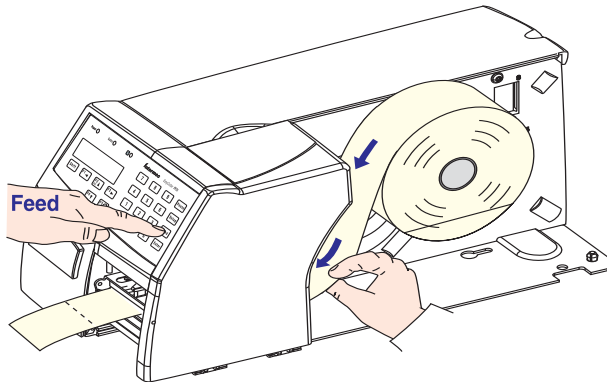

- 6 To tear off the media, grab the outer edge and pull downwards.

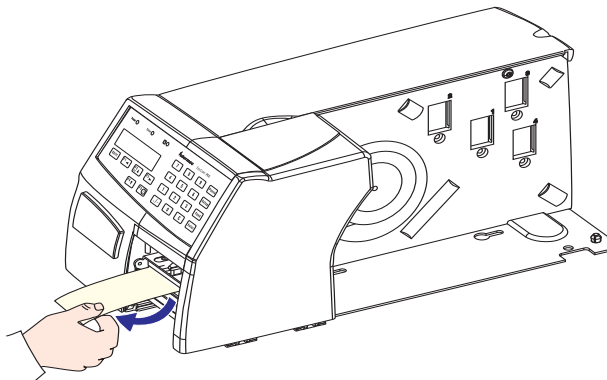

Peel-Off (Self-Strip)

The EasyCoder PF2i printer can print on labels, tickets, tags, and continuous stock in various forms. This section describes the case when self-adhesive labels are separated from the liner immediately after printing. The liner is then wound up on an integral liner takeup hub. This is also known as “Self-strip” operation.

Peel-off operation cannot be performed when quick-load guides are fitted.

Use the **Feed** key when loading the same type of media. When switching to a new type of media, or if the printer does not feed out the media properly, simultaneously press the **Shift** and **Feed** keys to perform a “Testfeed.”

Peel-off can only be used for:

- Self-adhesive labels with liner

An optional label-taken sensor can hold the printing of the next label in a batch until the present label has been removed, see “[Label Taken Sensor](#)” on page 91.



Note: Peel-off operation sets high demands on the media in regard of label stiffness, release characteristics of the adhesive and liner, resistance against electrostatic charging etc., so the labels will be dispensed properly. Consult your media supplier or test the media to ascertain that it is suitable for your application.

To load Peel-Off media

- 1 Open the side door.

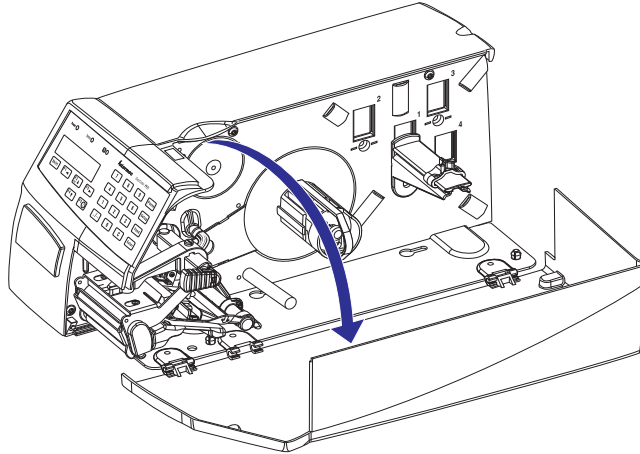

- 2 Turn the printhead lift lever clockwise to raise the printhead.

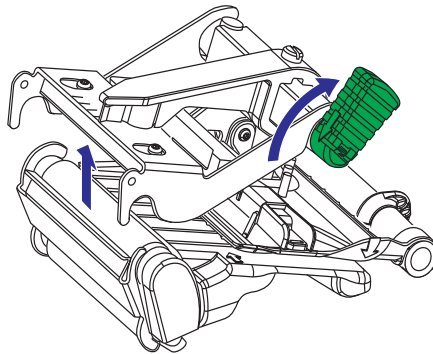

- 3 Pull out the handle to collapse the takeup hub, then remove any liner.

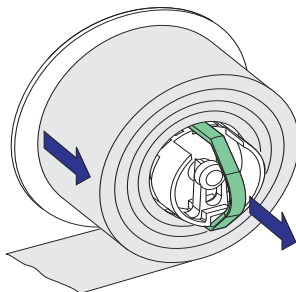

- 4 Remove an empty core from the media supply roll post.

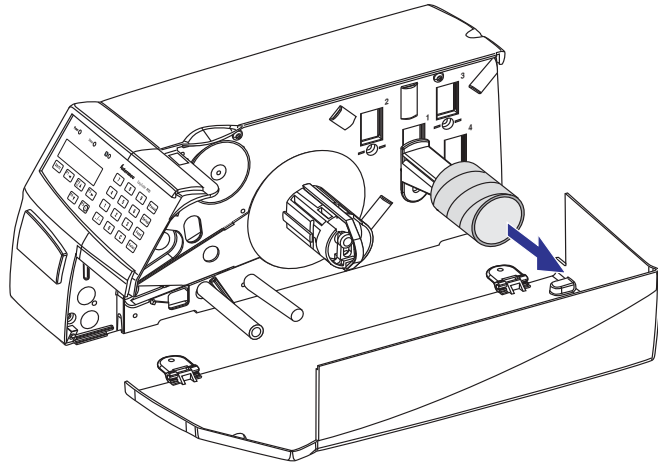

- 5 Fit a new roll of labels on the supply post and adjust the edge guide, so the label roll becomes flush with the center section.

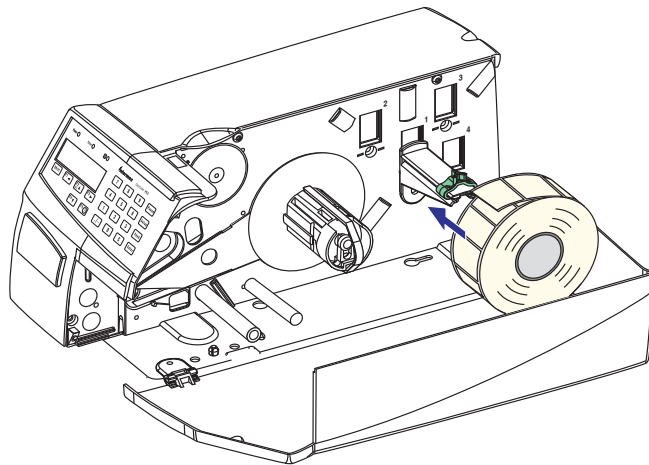

- 6 Remove labels from the first 50 cm (20 inches) of the liner. Route the liner through the print mechanism and push it inwards.

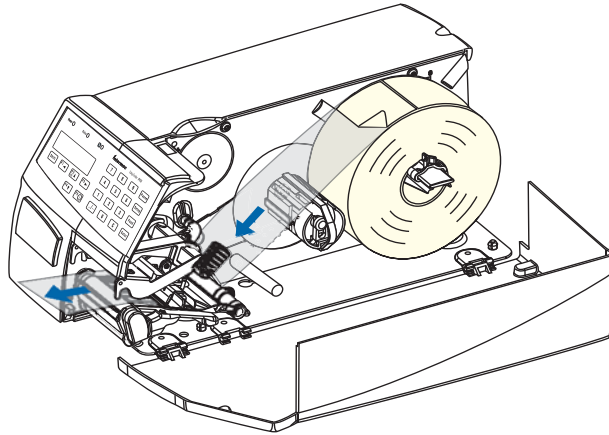

- 7 Route the liner around the tear bar and the liner drive roller and back under the print mechanism and guide shaft.

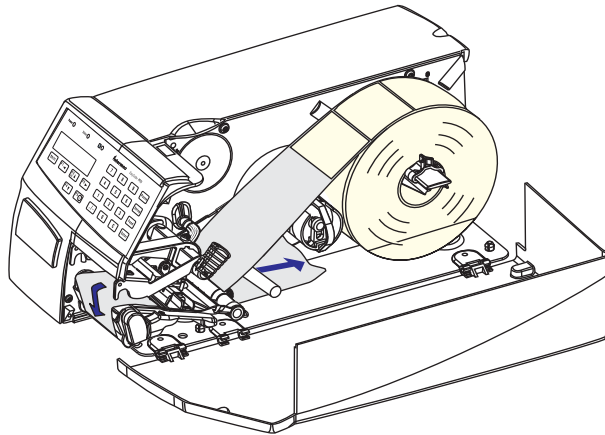

- 8 Insert the start of the liner under the lip of the takeup hub, then rotate the hub counterclockwise a few turns to wind up some of the liner.

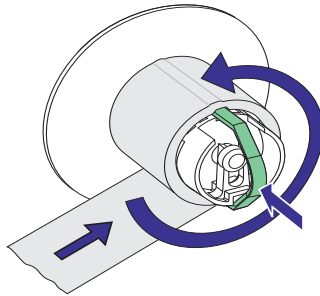

- 9 Press the handle to expand the takeup hub and secure the liner. Then rotate the hub counterclockwise until the liner becomes tight.

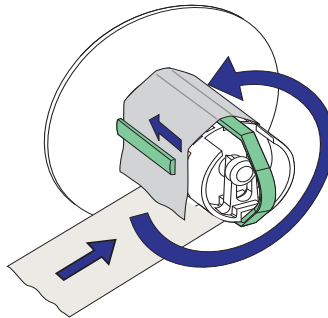

- 10 This diagram shows the media and liner paths.

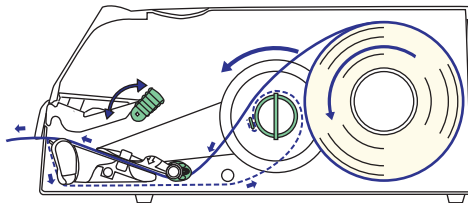

- 11 Turn the printhead lift lever counterclockwise to engage the printhead.

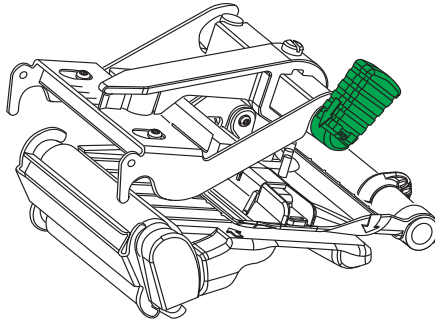

- 12 Adjust the position of the green edge guide, so the media is guided with a minimum of play.

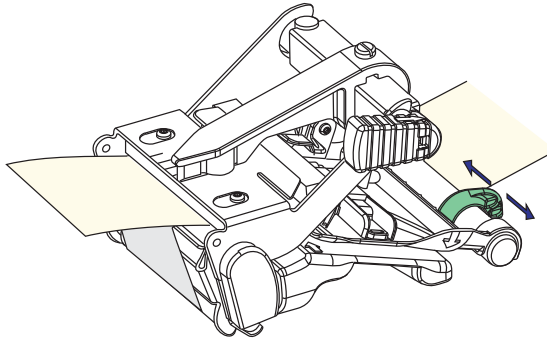

- 13 Close the side door.

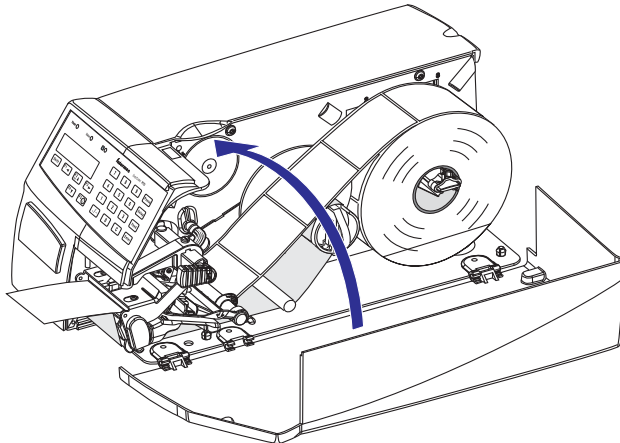

- 14 Press the **Feed** button to advance the media and adjust the media feed.

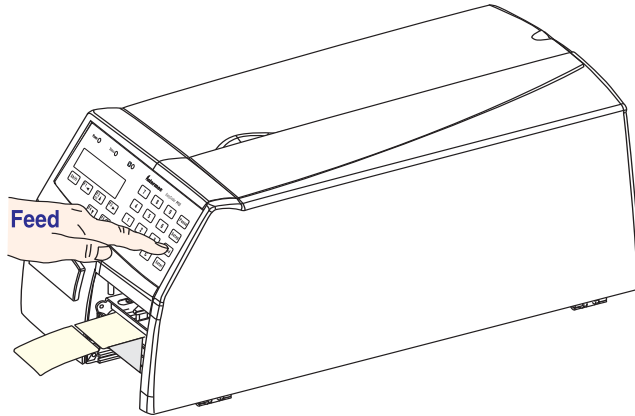

External Supply (Fan-Fold)

The EasyCoder PF2i printer can print on labels, tickets, tags, and continuous stock in various forms. This section describes the case when the media supply is placed behind the printer, usually in the form of fan-folded tickets or tags. External supply can be used with tear-off (straight-through) printing—preferably with quick-load.

External supply can be used with both short and long side doors and there is no need to remove the media supply roll post.

When using an external media supply, take care to protect the media from dust, dirt or other foreign particles, that can impair the printout quality or cause unnecessary wear to the printhead.

Depending on brand and quality, all direct thermal media are more or less sensitive to heat, direct sunlight, moisture, oil, plasticizers, fat, and other substances. You should protect them accordingly.

Chapter 4 — Media Load

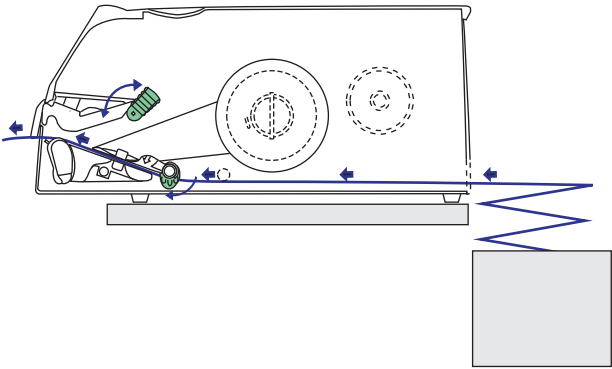

This diagram shows the media path from an external supply. In case of the standard edge guide (as opposed to quick-load guides), turn it to the vertical position.



5 Thermal Transfer Printing

This chapter explains how to load the printer with ribbon for thermal transfer printing when the printer is fitted with an optional transfer ribbon mechanism.

Ribbon Load

The EasyCoder PF2i printer can print on labels, tickets, tags, and continuous stock using either direct thermal printing on special heat-sensitive media or thermal transfer printing using a special ink-coated ribbon. For thermal transfer printing, the printer must be fitted with a transfer ribbon mechanism.

Thermal transfer printing makes it possible to use a wide range of receiving face materials and gives a durable printout less vulnerable to fat, chemicals, heat, sunlight etc. than direct thermal printing. Make sure to select a type of ribbon that matches the type of receiving face material and to set up the printer accordingly.

The EasyCoder PF2i printer can use transfer ribbon rolls wound with the ink-coated side facing either outward or inward. Illustrations in this manual show the ink-coated side facing inward.

Even if ribbon usually is loaded in connection with media replenishment, no loaded media are shown in the illustrations in this chapter in order to give a clearer view of the ribbon path. Refer to [“Ribbon Load” on page 42](#) for media load instructions.

Most transfer ribbons do not smear at room temperature.

To load transfer ribbon mechanism

- 1 Open the side door.

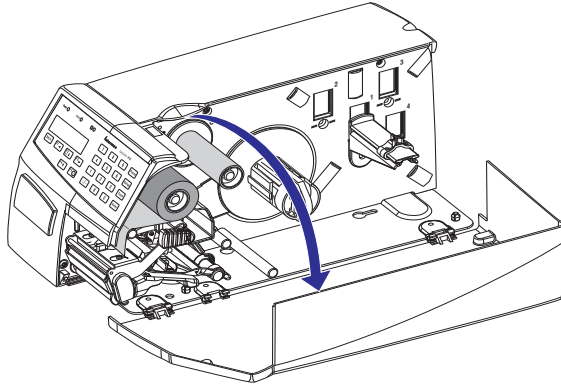

- 2 Turn the printhead lift lever clockwise to raise the printhead.

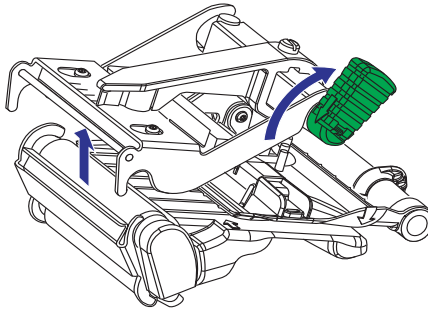

- 3 In case of ribbon reload, remove any used ribbon and empty ribbon core.

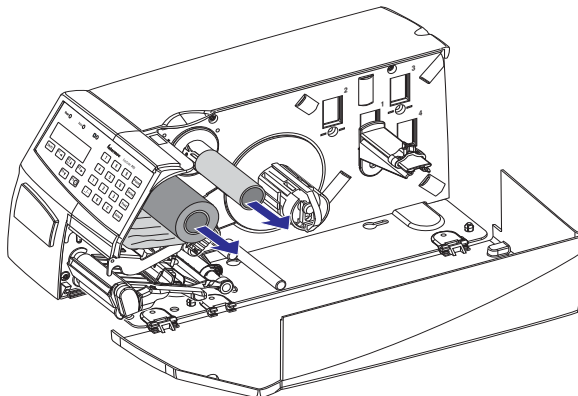

- 4 Unpack a roll of original Intermec thermal transfer ribbon.

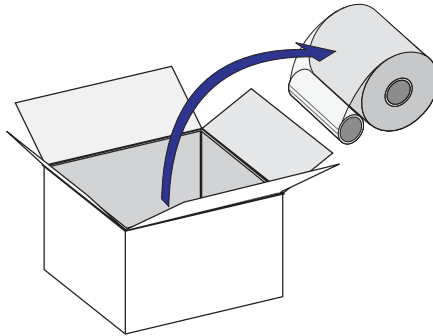

- 5 Slide the ribbon roll onto the supply hub, so the ink-coated side faces down when the ribbon is routed through the print mechanism.

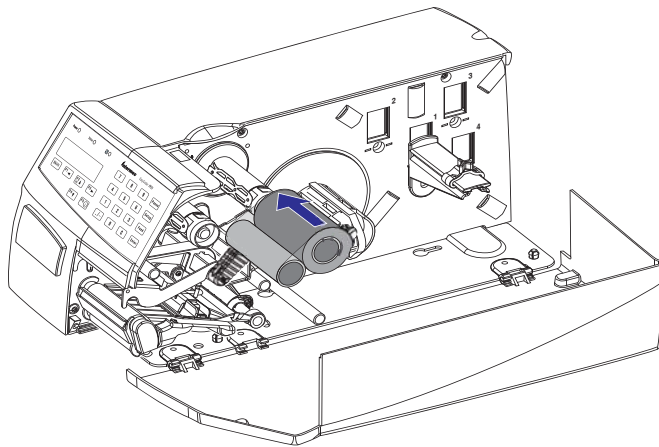

- 6 Route the ribbon through the print mechanism and pull out approximately 20 cm (8 inches) of ribbon.

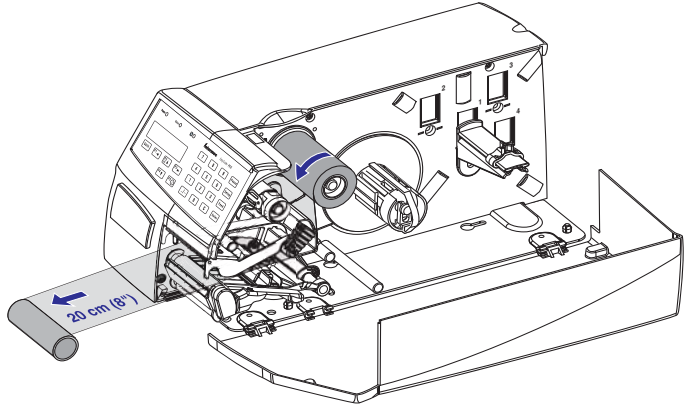

- 7 Without releasing the ribbon, turn the printhead lift lever counterclockwise to engage the printhead and lock the ribbon.

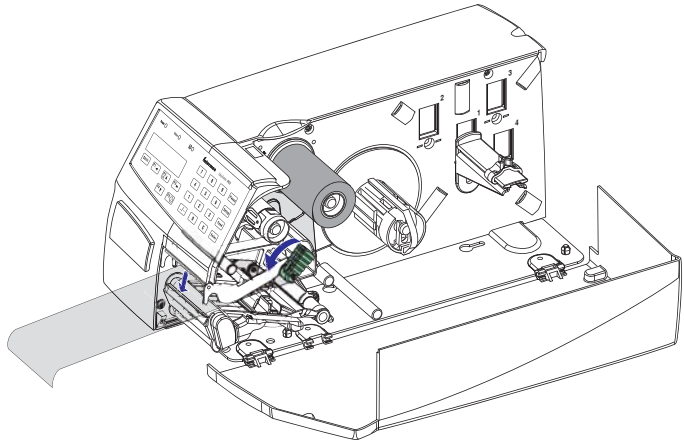

- 8 Slide the empty cardboard core onto the ribbon rewind hub, so the ribbon is wound up when the hub rotates counterclockwise.

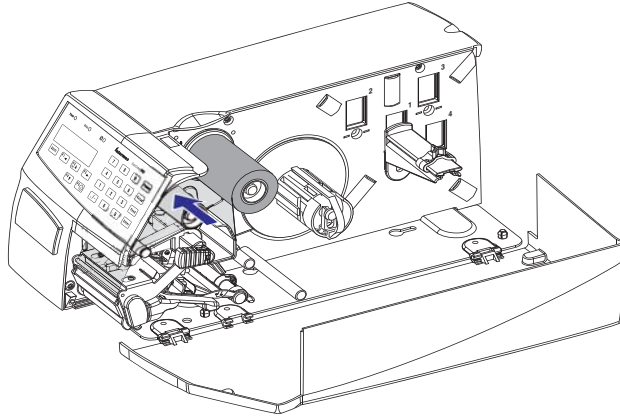

- 9 Turn the printhead lift lever clockwise to raise the printhead and release the ribbon.

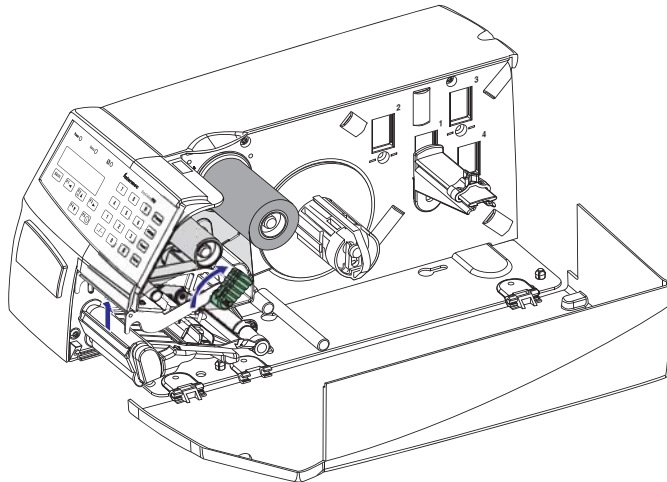

- 10 Manually advance the ribbon until all of the transparent leader has passed the printhead and the ribbon becomes tight.

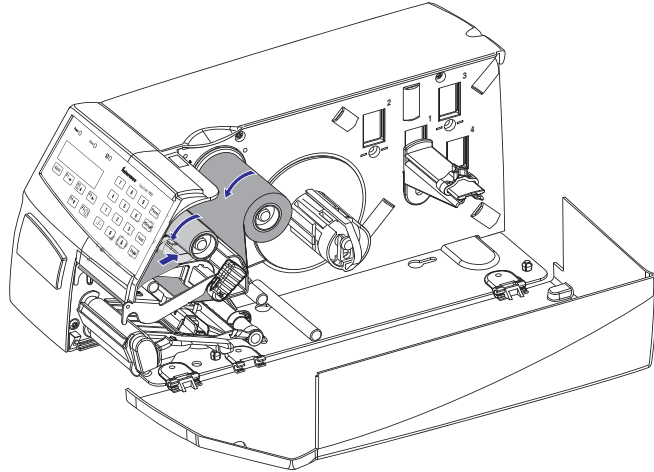

- 11 Turn the printhead lift knob counterclockwise to engage the printhead.

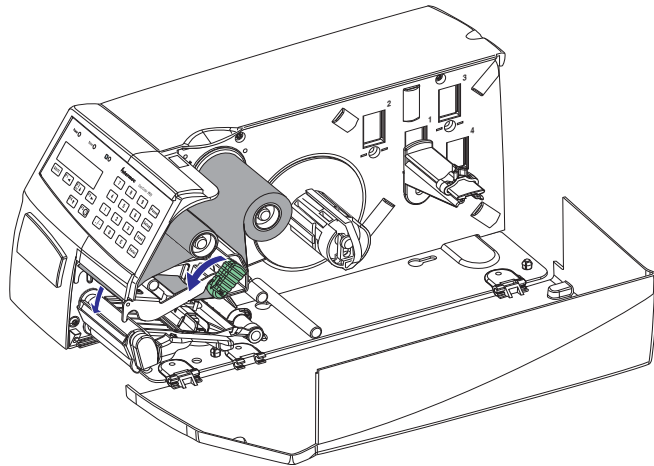

12 Close the side door.

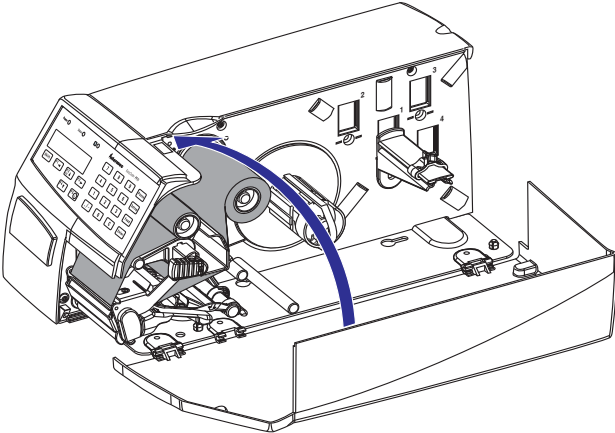



6 Setting Up the Printer

This chapter describes the various parameters that are used in the Setup Mode or in the various application programs to configure the printer for the user's specific requirements. It covers the following topics:

- Description
- Default Setup
- Setup Parameters

Description

The setup controls the printer in regard of serial communication, test and service operations, and specifies which type of media and (optionally) ribbon is loaded in the printer.

Check the list of the printer's default setup parameters on the next page to see if they match your requirements. If not, you will have to change the setup using one of the methods described below. The setup may also be changed by Intermec PrintSet, InterDriver, and LabelShop, or third-part application programs.

Setup Mode

- Press the **Setup** key on the printer's built-in keyboard to enter the Setup Mode.
- Select the Setup option in Intermec Shell to enter the Setup Mode.
- Execute the Intermec Fingerprint SETUP instruction to enter the Setup Mode.
- Access the Setup Mode via the printer's home (requires an optional EasyLAN interface board).

See “**Setup Mode**” on page 67 and the EasyLAN documentation.

Intermec Fingerprint

- Use setup strings to change individual setup parameters remotely from the host.
- Use setup files to create sets of setup parameters remotely from the host.

See the Intermec Fingerprint manuals.

Intermec Direct Protocol

- Use setup strings to change individual setup parameters remotely from the host.

See the *Intermec Direct Protocol v8.xx Programmer's Reference Manual* (P/N 1-960597-xx).

Default Setup

The printer's default setup is listed below (no options included):

Ser-Com "uart1:"	
Baud rate	9600 bps
Data bits	8 bits
Parity	None
Stop bits	1 bit
RTS/CTS	Disable
ENQ/ACK	Disable
XON/XOFF, data to host	Disable
XON/XOFF, data from host	Disable
New line	CR/LF
Receive buffer	1024 bytes
Transmit buffer	1024 bytes

Media	
X-Start	24
Width	424
Label length	1200
Media type	Label (with Gaps)
Paper type	Direct Thermal
Label Constant	85
Label factor	40
Contrast	±0%

Configuration	
Print speed	100 mm/sec.

Feed Adjust	
Start adjust	0
Stop adjust	0

Reading the Current Setup

The printer's current setup values can be read from the printer's display window by browsing through the Setup Mode.

You can list the printer's current setup values by printing test label "Setup Info" in the Setup Mode or by using Intermec Shell.

The current setup values can be sent to the host via the standard serial communication channel using a **SETUP WRITE "uart1:"** statement (see *Intermec Fingerprint v8.xx, Command Reference Manual*).

Setup Parameters

Serial Communication

The serial communication parameters control the communication between the printer and the connected computer or other devices on the serial port "uart1:" and the optional serial ports "uart2:" and "uart3:". The optional ports require an optional interface board. The printer's firmware detects if an interface board is installed in the printer and presents additional sets of communication setup menus depending on type of communication (refer to "[Setup Mode Overviews](#)" on page 71).



Note: The serial communication parameters have no effect on parallel or EasyLAN communication, or on the IN and OUT ports on the optional Industrial Interface Board.

For the serial communication channel "uart1:", the following parameters can be set. Make sure the printer's communication parameters match the setup of the connected device or vice versa. If the setup of the printer and the setup of the host do not match, the response from the printer to host will be garbled.

Baud Rate

The baud rate is the transmission speed in bits per second. There are 10 options:

- 300
- 600
- 1200
- 2400

- 4800
- 9600 (default)
- 19200
- 38400
- 57600
- 115200

Data Bits

The data bits parameter specifies the number of bits that will define a character. Eight bits are recommended, because that option allows more special characters and characters specific to foreign languages to be used. Refer to the *Intermec Fingerprint v8.xx, Command Reference Manual* for more information.

- 7: Characters ASCII 000 to 127 decimal
- 8: Characters ASCII 000 to 255 decimal (default)

Parity

The parity decides how the firmware will check for transmission errors. There are five options:

- None (default)
- Even
- Odd
- Mark
- Space

Stop Bits

The number of stop bits specifies how many bits will define the end of a character. There are two options:

- 1 (default)
- 2

Flow Control

RTS/CTS is a protocol where the communication is controlled by currents through separate lines in the cable being set either to high or low. By default, this option is disabled.

RTS high indicates that the transmitting unit is able to receive characters. RTS low indicates that the receive buffer is filled to 75% (see XON/XOFF).

CTS high indicates that the unit transmitting the CTS signal is ready to receive data. CTS low indicates that the receive buffer is full (see XON/XOFF). In some computer programs, for example MS Windows Terminal, RTS/CTS is designated “Hardware.”

ENQ/ACK is a protocol where the communication is controlled by the control characters ENQ (ASCII 05 dec.) and ACK (ASCII 06 dec.) being transmitted on the same line as the data. The sending unit transmits ENQ at regular intervals. If the response ACK is not received, the transmission is held up awaiting an ACK character from the receiving unit. By default, ENQ/ACK is disabled.

XON/XOFF is a protocol where the communication is controlled by the control characters XON (ASCII 17 dec.) and XOFF (ASCII 19 dec.) being transmitted on the same line as the data. XON/XOFF can be enabled/disabled separately for data received from the host by the printer (printer sends XON/XOFF) and for data transmitted to the host from the printer (host sends XON/XOFF).

XOFF is sent from the printer when its receive buffer is filled to 75%, and the transmission from the host is held, waiting for an XON character. When enough data have been processed so the receive buffer is filled only to 50%, the printer sends an XON character and the host resumes transmitting data. The same principles apply to XON/XOFF sent by the host, even if the percentage figure may differ. By default, XON/XOFF is disabled for data in both directions.

New Line

Selects the character(s) transmitted from the printer to specify the switching to a new line. There are three options:

- CR/LF ASCII 13 + 10 dec. (default)
- LF ASCII 10 dec.
- CR ASCII 13 dec.

Receive Buffer

The receive buffer stores the input data before processing. Default size is 1024 bytes.

Transmit Buffer

The transmit buffer stores the output data to be transmitted before transmission. Default size is 1024 bytes.

Feed Adjust

The Feed Adjust part of the Setup Mode controls how much of the media is fed out or pulled back before and/or after the actual printing. These settings are global and will be effected regardless of which program is run.



Note: The firmware uses the front edges of labels with gaps, the ends of detection slots, and the forward edges of black marks for detection, all seen in relation to the feed direction.

Start Adjust

The Start Adjust value is given as a positive or negative number of dots (1 dot = 0.125 mm = 4.9 mils). Default value is 0, which places the origin a certain distance back from the forward edge of the copy.

- A **positive** start adjustment means that the specified length of media will be fed out before the printing starts. Thus, the origin is moved further back from the forward edge of the copy.
- A **negative** start adjustment means that the specified length of media will be pulled back before the printing starts. Thus, the origin is moved towards the forward edge of the copy.

Stop Adjust

The Stop Adjust value is given as a positive or negative number of dots (1 dot = 0.125 mm = 4.9 mils). Default value is 0, which stops the media feed in a position suitable for tear off operation.

- A positive stop adjustment means that the normal media feed after the printing is completed will be increased by the specified value.
- A negative stop adjustment means that the normal media feed after the printing is completed will be decreased by the specified value.

Recommended Feed Adjustments

The following settings allow printing from the top of the label. Minor deviations from the recommended values may be required due to various combinations of media types, roll size, type of media supply device, and individual differences between printers.

Tear-Off (Straight-Through)	
Start adjust	-100 dots (12.5mm/0.49 in.)
Stop adjust	0 dots

Peel-Off (Self-Strip)	
Start adjust	-56 dots (7 mm/0.28 in.)
Stop adjust	-44 dots (5.5 mm/0.22 in.)

Media

The media parameters tell the firmware the characteristics of the media that will be used, so the printout will be positioned correctly and get the best quality possible.

Media Size

The size of the printable area is defined by three parameters; X-Start, Width, and Length.

X-Start

Specifies the position of the origin along the dots on the printhead.

By default, X-Start is 24 dots, which places the inner margin of the print area 3 mm (0.118 inches) from the inner edge of the media and gives a maximum print width of 424 dots (53 mm/ 2.087 inches). This prevents printing outside labels when the liner is slightly wider than the labels.

If you want to use the entire media width, reset the X-Start value to 0 which gives a maximum print width of 448 dots (56 mm/ 2.205 inches).

By increasing the value for the X-Start parameter, the origin will be moved outwards, away from the inner edge of the media path. In other words, the larger X-Start value, the wider inner margin and the less available print width.

Width

Specifies the width of the printable area in number of dots from the origin. Thus, the sum of the X-Start and width values gives the outer margin of the printable area. The width should be set to prevent printing outside the media, which may harm the printhead.

Length

Specifies the length of the printable area in number of dots from the origin along the Y-coordinate and allocates memory space for two identical image buffers in the printer's temporary memory.

The size of each buffer can be calculated using this formula:

$$\text{Buffer size (bits)} = [\text{Print length in dots}] \times [\text{Printhead width in dots}]$$

Note: The temporary memory has other functions that also require some memory space. To obtain a longer print area, the memory can be increased by fitting a larger SDRAM SIMM on the printer's CPU board as described in the Service Manual.

- The length setup also decides the amount of media feed when using “fix length strip.”
- The length setup creates an emergency stop, which works when the printer is set up for “Label (with gaps)”, “Ticket (with mark)”, or “Ticket (with gaps).” If the label stop sensor (LSS) has not detected a gap or mark within 150% of the set length, the media feed is automatically stopped to avoid feeding out a whole roll of media, because of an LSS malfunction.

By setting up the X-Start, the Width, and the Length, you will create a print window inside which the printing can be performed. Any object or field extending outside the print window in any direction will either be clipped or cause an error condition (Error 1003 “Field out of label”), see *Intermec Fingerprint v8.xx, Command Reference Manual*.

Print Window

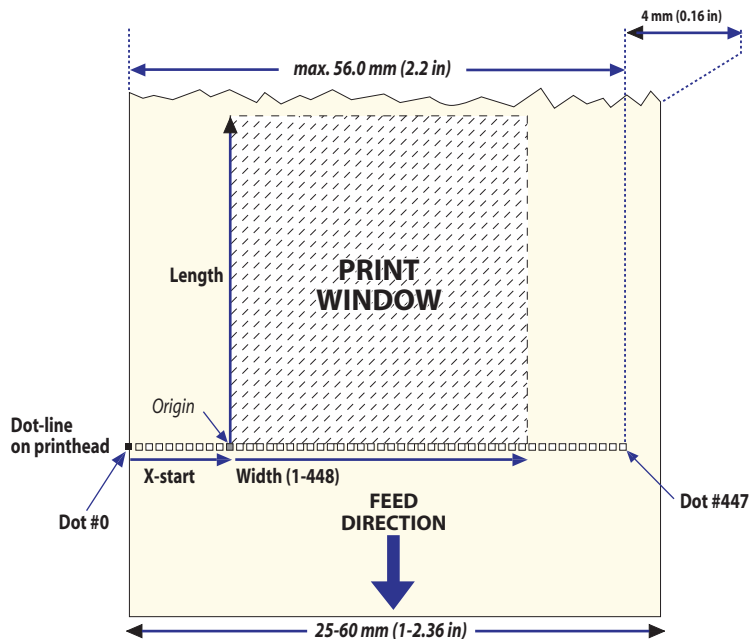

Media Type

The Media Type parameters control how the label stop sensor (LSS) and the media feed work. There are five media type options:

- **Label (with gaps)** is used for adhesive labels mounted on liner.
- **Ticket (with mark)** is used for labels, tickets, or continuous stock provided with black marks at the back.
- **Ticket (with gaps)** is used for tickets and tags with detection slits.
- **Fix length strip** is used for continuous stock where the length of the print window decides the length of media to be fed out.
- **Var length strip** is used for continuous stock. The size of the print image decides the length of each copy.

It is important to select the correct media type, so the printer can indicate the following errors.

- Error 1005 “Out of paper” indicates that the last ordered copy could not be printed because of an empty media stock.
- Error 1031 “Next label not found” indicates that the last ordered label or ticket was successfully printed, but no more labels/tickets can be printed because of an empty media stock.

Paper Type

The Paper Type parameters control the heat emitted from the printhead to the direct thermal media or optionally the transfer ribbon in order to produce the dots that make up the printout image.

Labels, tickets, tags, strip, and ribbons for various types of application are available from Intermec. For the best printout quality and maximum life of the printhead, use Intermec supplies. Setup recommendations for Intermec supplies offered in Europe and North America are listed in Appendix D.

As a general rule, high energy and/or high print speed will shorten the life of the printhead. Never use higher paper type and print speed settings than necessary for obtaining an acceptable printout quality and throughput speed.

If the ambient temperature is lower than +15°C (+59°F), decrease the speed by 50 mm/sec.

Start by choosing between two alternatives:

- Direct Thermal printing (default)
- Thermal Transfer printing (option)

Your choice will decide which parameters to enter next:

Direct Thermal Printing

- Label Constant (range 50 to 115)
- Label Factor (range 10 to 50)

When adjusting the image darkness for non-Intermec direct thermal media, set the Label Factor to the recommended value for the type of direct thermal media. Set the Label Constant to the value listed below and decrease or increase it for lighter or darker images respectively until you are satisfied with the printout quality.

General Paper Type Settings Guide (Direct Thermal)

Sensitivity¹	Label Constant	Label Factor	Max. Print Speed
Low	100	50	150
Standard	90	50	150
High	80	50	200
Ultra High	70	50	200

1. Note that the preprint and varnish decrease the sensitivity of direct thermal media.

Thermal Transfer Printing

- Ribbon Constant (range 50 to 115)
- Ribbon Factor (range 10 to 50)
- Label Offset (range -50 to 50)
- Ribbon Sensor (auto-adjustment)
- Low Diameter (range 25 to 80 mm)

When adjusting the image darkness for non-Intermec media and transfer ribbons, set the Ribbon Factor to the recommended value for the type of thermal transfer ribbon. Set the Ribbon Constant to the value listed below and decrease or increase it for lighter or darker images respectively until you are satisfied with the printout quality. The Label Offset parameter is presently not used, so keep it at the default value 0.

General Paper Type Settings Guide (Thermal Transfer)

Type	Ribbon Constant	Ribbon Factor	Max. Print Speed
Wax (Europe)	70	25	150
Wax (U.S.A.)	70	25	150

General Paper Type Settings Guide (Thermal Transfer) (continued)

Type	Ribbon Constant	Ribbon Factor	Max. Print Speed
Wax/Resin (Europe)	80	25	150-200
Wax/Resin (U.S.A.)	90	25	150-200
Resin (Europe)	90	30	200
Resin (U.S.A.)	95	30	200

The Ribbon Sensor parameter is read-only. When performing a Testfeed or when pressing the **Enter** key when the Ribbon Sensor menu is displayed, the printer will feed out some media and autoadjust the sensor. The resulting setting is displayed in the menu.

The Low Diameter parameter specifies the diameter of the ribbon supply roll, where SYSVAR(26) switches from 0 to 1. SYSVAR(26) = 0 means that there is still a sufficient supply of ribbon, whereas SYSVAR(26) = 1 means that it is time to consider replacing the ribbon supply. The diameter is expressed in millimeters (1 mm = 0.04 in.) and an accuracy of ± 3 mm can be expected. Note that this setting has little effect unless SYSVAR(26) is read by a Fingerprint program. However, Error 1083 “Ribbon Low” is reported at every tenth printing operation. By default, the low diameter is 0, that is, the ribbon low function is disabled.

Contrast

Use the contrast parameter to make minor adjustments of the blackness in the printout, for example to adapt the printer to variations in quality between different batches of the same media. 11 options are displayed in an endless loop from -10% to +10%. Default value is 0%. The contrast is reset to the default (± 0) whenever a new paper type is specified, regardless which method has been used.

Testfeed

The sensitivity of the label stop sensor (LSS) may need to be adjusted when switching from one type of media to another. This is especially the case when using adhesive labels since the transparency of the liner (backing paper) may vary. When the Testfeed menu is displayed, press the **Enter** key. A number of blank copies will be fed out until the firmware has decided the proper setting for the LSS. At the same time, the front edges of the labels, tickets, etc. are detected so the feed control can position the media according to the Feed Adjust parameter (same as the Intermec Fingerprint statement TESTFEED). Four values used for troubleshooting the LSS are displayed (read-only information).

Print Defines



Head Resistance

The printhead resistance is measured automatically at startup (read-only information).

Testprint

The test labels “Diamonds”, “Chess”, “Bar Codes #1”, and “Bar Codes” are used to check the printout quality and facilitate adjustment of the printhead pressure, see [“Printhead Pressure Adjustment” on page 121](#). The test labels “Setup Info” and “Hardware info” list the printer’s current setup and the installed electronic devices. Test label “Network Info” is only printed if the printer has an optional EasyLAN interface board. If the information does not fit on one label, two or more labels will be printed. If the printer refuses to print a test label, press the **i** key to find out what is wrong, for example “printhead lifted” or “out-of paper”.

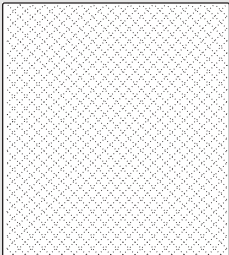
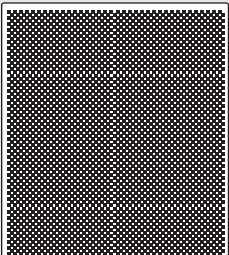
Test Labels

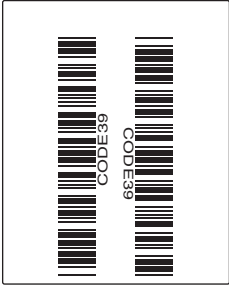
 <p>706 ohms/8 dots</p>		
<p>Diamonds</p>	<p>Chess</p>	<p>Bar Codes #1</p>
	<pre> UARTI 9600-JE-N1 DISABLE DISABLE KONKOFF DISABLE DATA TO HOST DISABLE NEW LINE CR/LF REC BUF 3000 PRINT CONFIG 0 START/ADJ 24 WIDTH 424 MEDIA TYPE LABEL (w GAPS) PAPER TYPE DIRECT THERMAL L. FACTOR 8 L. ADJ. FACT 1 LABEL FACTOR 40 </pre>	<pre> CONTRACT 10% HEAD RESIST 706 PRINT SPEED 100 IP ADDRESS 192.168.255.104 NETMASK 255.255.254.0 NAME SERVER 192.168.254.20 FIRMWARE (version number) Fingerprint MCS (number, date, time, and processor family) </pre>
<p>Bar Codes #2</p>	<p>Setup Info (1/2)</p>	<p>Setup Info (2/2)</p>
<pre> Model Name 1-571020-501/PFU/1.0/001-000000 1-571020-507/Canon/1.0/003-000000 1-571020-501/CFU/1.0/000-000015 Email:AM/00104617892 Model PF2 Hardware version 4.0 (3.1C version 1) Compass/Flash 0 (N) Capacity 6000000 bytes free C: 0 Chamber 0 (R) </pre>		
<p>Hardware Info</p>		

Print Speed

The print speed is variable between 100 and 200 mm/sec. Generally, the lower the speed, the better the printout quality. This is especially true when printing bar codes with the bars running across the media path (“ladder style”), when printing on demanding face materials, and when printing at low ambient temperatures. The default setting is 100 mm/sec. (approximately 4 inches/sec.).



The combination of a large media roll (>152 mm/6 inches diameter) and/or narrow media width in combination with high print speed (>150 mm/6 inches per sec.) could cause jerks in the media feed. Such jerks will compress text and spoil the readability of ladder-style bar codes placed close to the front edge of the label. In case of batch printing, only the first label in the batch will be affected. Negative start adjust values tend to increase the jerks.

- If the media roll is larger than 152 mm (6 inches), do not use a print speed >150 mm/sec.
- If a negative start adjust is used, do not use a print speed >125 mm/sec.
- Narrow media width may require further restrictions on print speed.
- Avoid placing text and ladder-style bar codes close to the front edge of labels.

LSS Test

The function on the label stop sensor (LSS) can be tested automatically or manually as described in [“Adjustments” on page 115](#).

LTS (Label Taken Sensor)

The sensitivity of the LTS can be tested and adjusted as described in [“Adjustments” on page 115](#).

Returning to Factory Default Setup

There are two ways to return to the factory default setup of the printer:

- Insert a special CompactFlash memory card and restart the printer.
- Using the printer's built-in keyboard.

To reset the printer using the keyboard:

- 1** Lift the printhead.
- 2** Switch on the power to the printer and press the **i/F5** key and wait until the printer beeps.

3 Quickly press the following keys in this order:

▼/F4, ▲/F2, ▲/F2, ◀/F1

4 The following message will be displayed:

```
Factory Default?  
Enter=Yes ESC=No
```

5 Within 10 seconds, press **Enter** to reset the printer to factory default. The parameters will be reset and the printer will continue the normal startup.

If you press ▲/F2 or wait until the 10 seconds timeout has passed, the normal startup will continue without any reset being performed.



Note: If any of the files "card:NOSHELL.CFG", "rom:NOSHELL.CFG", or "c:NOSHELL.CFG" exists in the printer's memory, no reset to factory default will be performed.

The factory default will remove all files used to store settings. It will not reset settings that already has been read when the files are removed. This means that EasyLAN Wireless settings (SSID, keys, etc.) will retain their values from the previous start. However, the next reboot will reset them to factory default.



7 Setup Mode

This chapter describes how to enter the setup mode at installation, explains how to navigate in the setup mode, and provides overviews over which parameters and messages are available for the standard printer and with various interface boards.

Entering Setup Mode at Installation

The method of entering the Setup Mode depends on which startup files are stored in the printer's memory, a subject that was more thoroughly discussed in “[Starting Up](#)” on page 19.

EasyCoder PF2i with Intermec Shell

- Switch on the power.
- When the display shows the message “Enter=Shell; x sec...”, press the **Enter** key.
- Press the **Setup** key (this facility can be used anywhere within Intermec Shell and also outside Intermec Shell provided there is no application program running that disables the **Setup** key).
- Set up the printer as described in this chapter.
- Exit the Setup Mode by pressing the **Setup** key.

EasyCoder PF2i with a custom-made application program

Normally, there is no need to enter the Setup Mode when using application programs that start up automatically. Necessary provisions for changing the setup, manually or automatically, should be provided by the program.











Navigating in Setup Mode

While going through the setup procedure, you are guided by texts in the printer's display. You can navigate between setup menus, acknowledge displayed values, select or enter new values, etc. by using the keys on the printer's keyboard.



Note: An external keyboard cannot be used in the Setup Mode.

Keyboard Buttons for Setup Mode

Button	Function
	Move one menu to the left on the same level or scroll back in a stack of options.
	Move up one level.
	Move one menu to the right on the same level or scroll forward in a stack of options.
	Move down one level.
	Display error messages at test label printing failure.
	Enter numeric values.
	Specify negative values (leading position).
	Clear displayed values.
	Acknowledge and move to next menu or perform test feeds in the Testfeed menu, or print test labels in the Test label menu.
	Exit the Setup Mode. Can be used anywhere in Setup Mode.

Chapter 7 — Setup Mode

The Setup Mode is organized as an endless loop, from which you can select a number of sub-categories. At startup, the firmware determines if options such as a label taken sensor, a cutter, or an interface board is installed in the printer. Only installed options are shown in the Setup Mode.

The diagram below shows the options in the main loop. Detailed overviews are shown on the pages that follow.

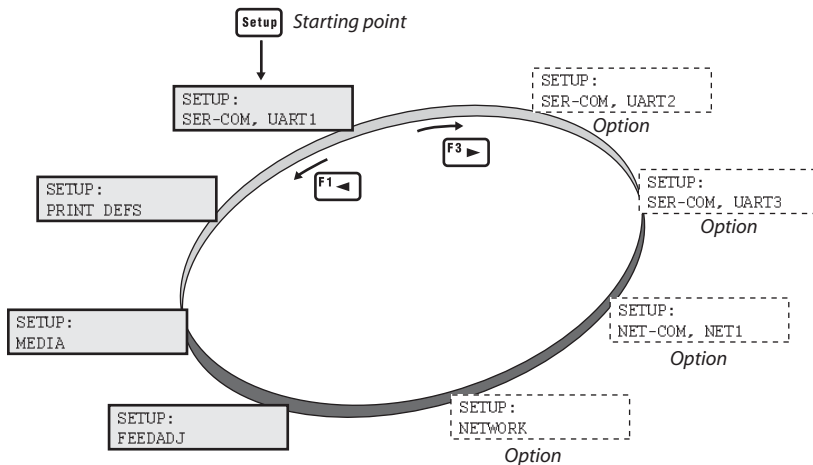

Setup Mode Overviews

Setup Mode; Serial Communication “uart1:” (Intermec Fingerprint v8.20)

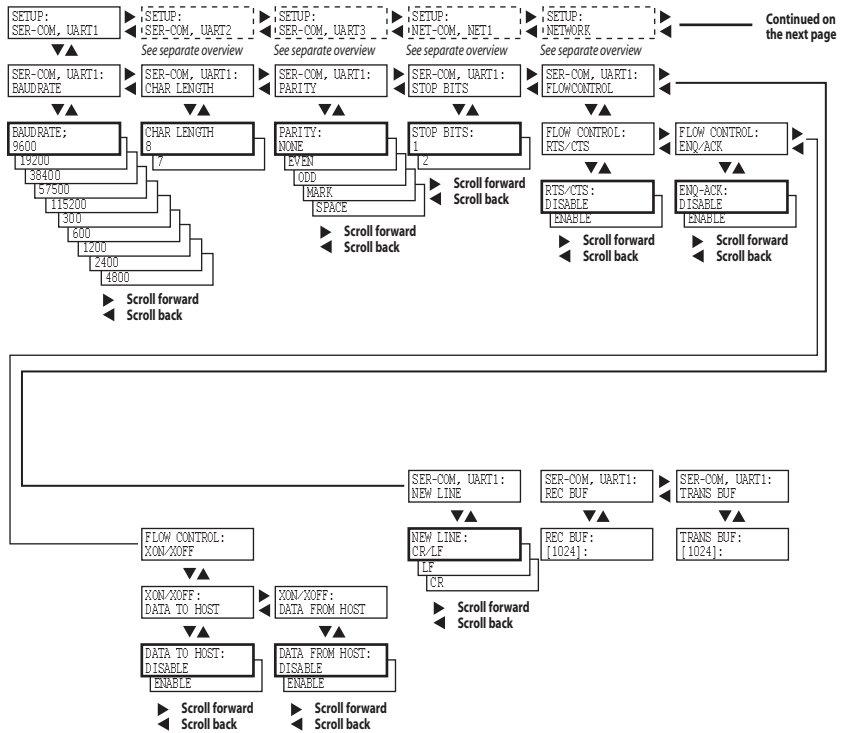

Legend:
 Dotted boxes and lines indicate options.
 Thick boxes indicates default options.
 Values inside brackets indicate default settings.

Setup Mode; Feed Adjust (Intermec Fingerprint v8.20)

Continued from the previous page

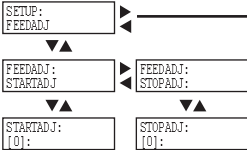

Continued on the next page

Setup Mode; Media (Intermec Fingerprint v8.20)

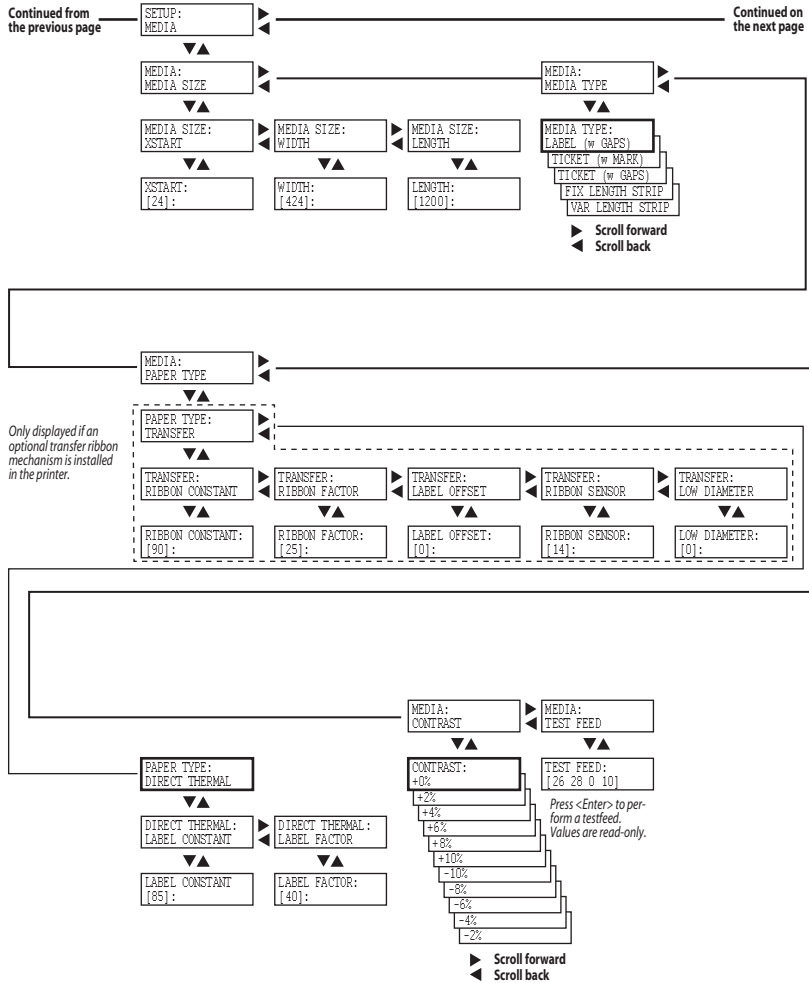

Setup Mode; Print Defs (Intermec Fingerprint v8.20)

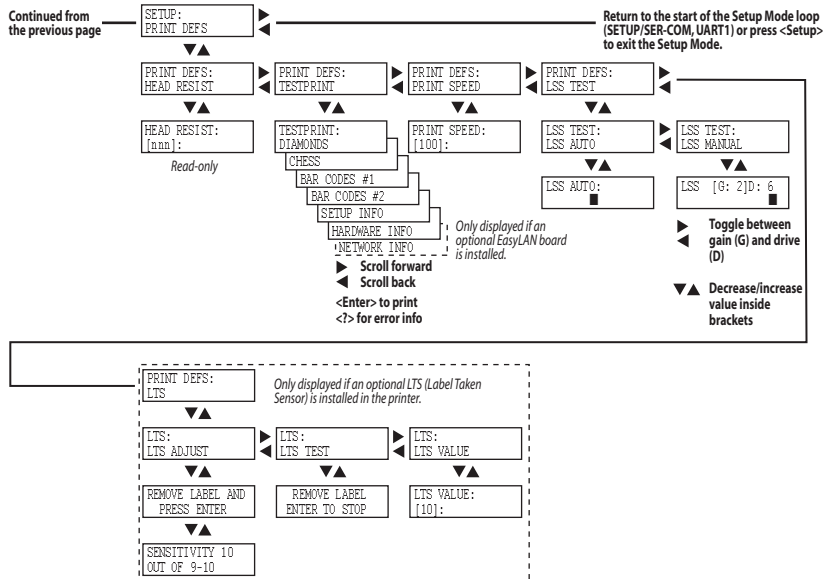

Setup Mode; Serial Communication “uart2:” (option) (Intermec Fingerprint v8.20)

These menus will only be displayed when an optional Double Serial or Serial/Industrial interface board is installed.
In case of a Double Serial interface board, also see the overview for Serial Communication, uart3.

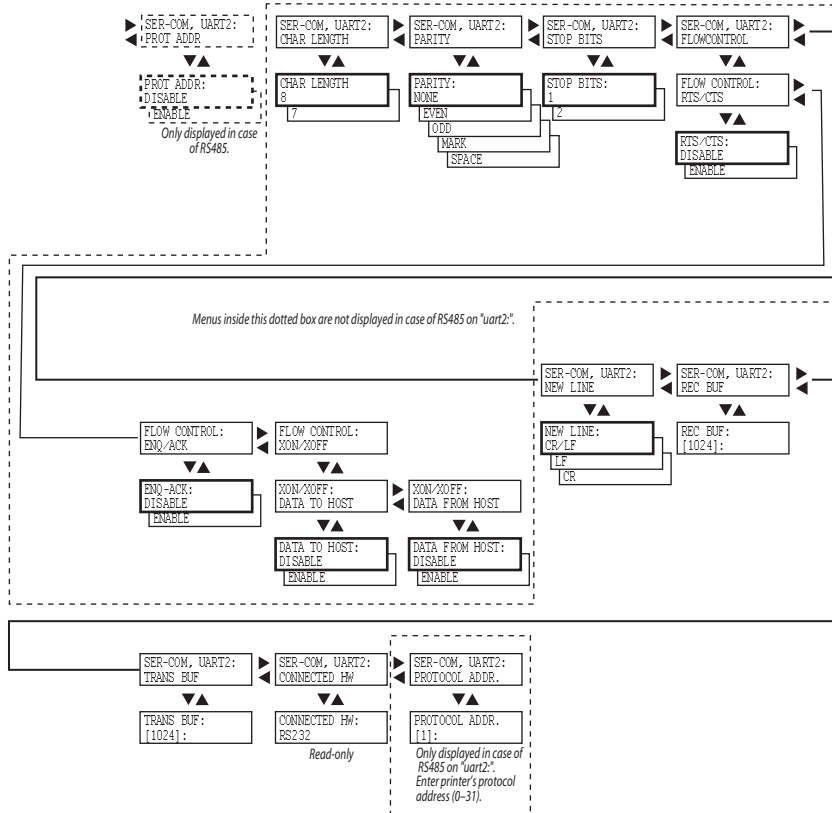

Setup Mode; Serial Communication “uart3:” (option) (Intermec Fingerprint v8.20)

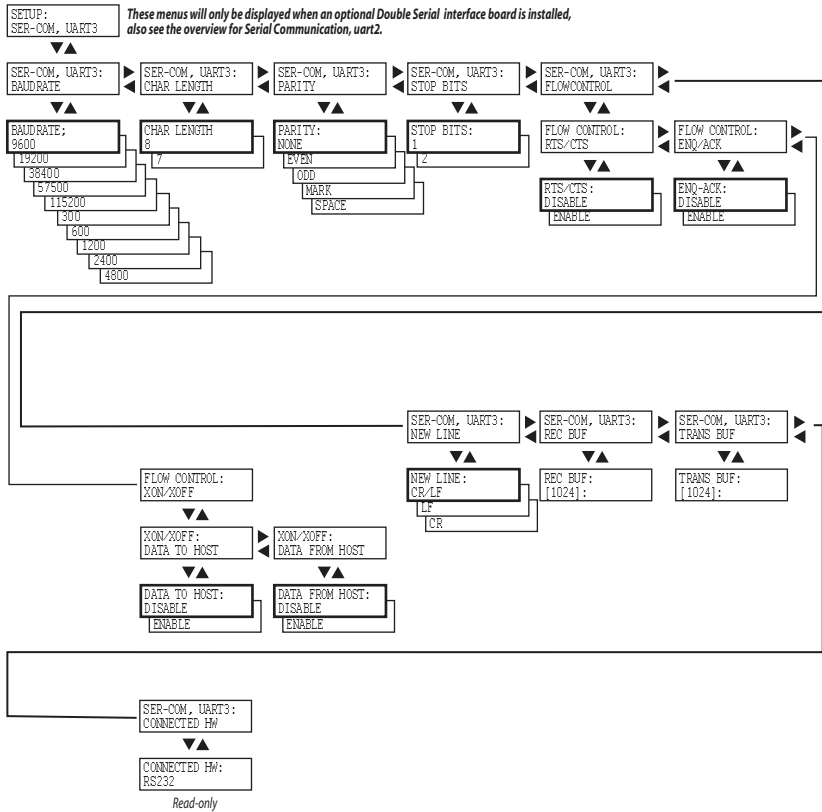

Setup Mode; Network Communication “net1:” (option) (Intermec Fingerprint v8.20)

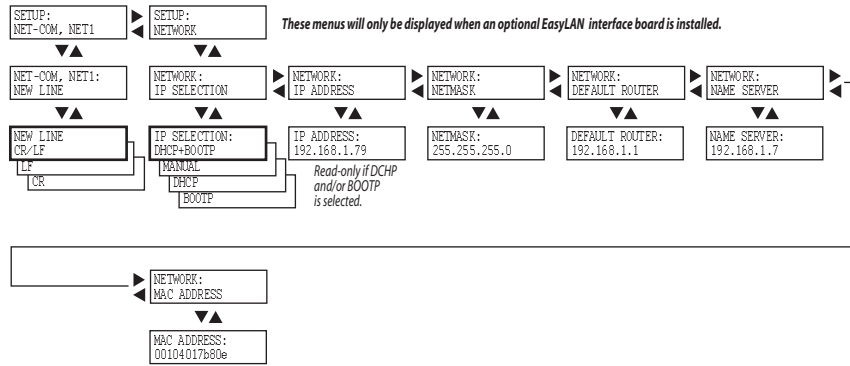



8 Intermec Shell Startup Program

This chapter describes the Intermec Shell Startup program and covers the following topics:

- Introduction
- Starting with Intermec Shell
- Intermec Shell Overview
- Line Analyzer

Introduction

Intermec Shell is a startup program, which is a program that automatically starts running when the printer is switched on. Intermec Shell helps the operator to choose between a number of standard or custom-made application programs and to start certain useful facilities, as listed below.

Application Programs

- Intermec Fingerprint (for creating your own programs or to run the Intermec InterDriver)
- Intermec Direct Protocol (easy-to-use slave protocol)
- LINE_AXP.PRG (line analyzer program)
- Other application programs in the printer's memory.

A prerequisite for a program to appear as an option in Intermec Shell is that the program is provided with the extension ".PRG" and is stored in the root of the directory "/c" or "card1:". However, some original Intermec utility programs are excluded as long as they remain stored in "/rom":

- ERRHAND.PRG
- FILELIST.PRG
- LBSHTXT.PRG
- KAUTO.PRG
- SHELLXP.PRG
- WINXP.PRG

Other Facilities

- Setup Mode (manual setup from printer's keyboard)
- Print Setup (printing setup on label)
- Testfeed (form feeds and auto-adjust of the LSS)
- Test Label (printing of test labels)
- Default setup (resetting all setup parameters to default)

- Software Update (downloading data from a host to a CompactFlash card in the printer, upgrading the printer's firmware from a Compact-Flash card, or upgrading the printer's firmware from a file in a PC)
- Reboot (restarting the printer)



Note: Intermec Shell is factory-installed in the printer's permanent memory (device "/rom"). If you insert a memory card with another startup file before you switch on the printer, or if there is a startup file stored in the printer's permanent memory (device "/c"), this startup file will be used instead of Intermec Shell (see “[Startup Files](#)” on page 20).

Starting with Intermec Shell

A few seconds after you have switched on the power to the printer and the initialization is completed, the countdown menu of the Intermec Shell program will be displayed:

```
ENTER=SHELL
5 sec. v.8.1
```

Now you have 5 seconds to enter Intermec Shell by pressing **Enter**. The lower line tells you how much time you have left. Should the time run out before you have taken any action, the last selected application in Intermec Shell will be opened. If you use the same application all the time, you will only need to switch on the power, once the application has been selected.

If no other application has yet been selected, the current version of Intermec Fingerprint will be opened with "auto" selected as std I/O channel (see Intermec Fingerprint manuals). When the countdown is completed, you will see these lines in the display:

```
FINGERPRINT
8.20
```

If you want to select another application, just cycle the power and enter Intermec Shell before the countdown is completed.

When you enter the Intermec Shell from the countdown menus, the Select Application menu will be displayed:

```
SHELL
SEL. APPLICATION
```

In this menu, you can choose between two options:

- Press **Enter** to go to menus where you can select an application program.
- Press **►** to go to the Facilities part of Intermec Shell.

Selecting an Application

In Intermec Shell, the menus present the options in infinite loops. To see all menus and options, refer to the overview in this chapter. The Select application lets you choose an application program that resides in the printer's memory:

- **Current appl.** starts the last selected application (by default Intermec Fingerprint with "auto" selected as standard I/O channel).
- **Fingerprint** is used to create, modify, or run programs written in the Intermec Fingerprint programming language and to run the Intermec InterDriver. This option requires that you also select a standard IN/OUT channel, which is the channel you want to use for communication between the printer and the computer. Normally, you select "uart1:". Refer to the Intermec Fingerprint manuals.
- **Direct Protocol** is an easy-to-use printer protocol for downloading label formats and variable input data to a printer from a host computer. This option requires that you also select a standard IN/OUT channel, that is the serial channel you want to use for communication between the printer and the host. Normally, you select "uart1:". Refer to the *Intermec Fingerprint v8.xx, Command Reference Manual*.
- **LINE-AXP.PRГ** (Line Analyzer) is a Fingerprint program that captures characters received by the printer on a communication channel and prints them on labels.
- Other Application Programs will be presented as additional options.



Note: When an application program is started, it may automatically change the communication setup. If another application is selected later, this communication setup will remain valid, unless the new application includes instructions that automatically change the setup. The setup could also be changed manually in the Setup Mode.

Selecting Other Facilities

As an alternative to selecting an application, you can step through a number of other useful facilities:

Setup

Set up the printer using its built-in keyboard, see [“Setup Mode” on page 67](#).

Print Setup

Produce a printout of the printer’s current setup values (test label “Setup Info”).

Testfeed

Feed out a number of label, ticket, tag, or portions of continuous stock while the printer auto-adjusts its media feed and label stop/black mark sensor. It is recommended to perform a Testfeed each time you load a roll of labels from a new batch or a different brand.

Test Label

Print a series of four test labels (test labels “Diamonds”, “Chess”, “Bar Codes #1”, and “Bar Codes #2”) in order to test the printout quality and printhead alignment. The labels are presented in an infinite loop, so you can print the series over and over again. Press **Enter** for each new label.

Default Setup

Reset all setup parameters to their default values, as listed in [“Setting Up the Printer” on page 49](#).

Software Update

Using the Zmodem communication tool, files can be downloaded from a PC, either to be stored on a standard CompactFlash memory card or to upgrade the printer’s firmware. The following options are available:

- Update CompactFlash card allows the printer to be used as a CompactFlash card programming device. Any files can be

downloaded from a PC to a standard CompactFlash card inserted in the memory card slot in the printer's rear plate.

A typical application is to create a firmware upgrade card from an upgrade file stored in a PC. You can use the card to upgrade the firmware in several printers simply by moving the card from printer to printer. Just insert the card, switch on the power, and wait from the prompts to appear in the printer's display window.

Update firmware is used to directly upgrade the firmware of a specific printer from a new firmware version stored as a file in a PC. If the printer is equipped with an EasyLAN Ethernet or Wireless board, the user must have access rights to upgrade the firmware, see the EasyLAN User's Guide for the Ethernet or Wireless board.



Caution

If the CompactFlash card or upgrade file contains an earlier firmware version than the one in the printer, the printer's firmware will be downgraded without warning.

Firmware upgrade files can be found on www.intermec.com or be obtained from your local Intermec distributor.

Reboot

Corresponds to cycling the power to the printer. To exit Intermec Shell without having selected any application, select Reboot. Then wait for the 5 seconds countdown to finish, and the last selected application will be opened.

Intermec Shell v8.1 Overview

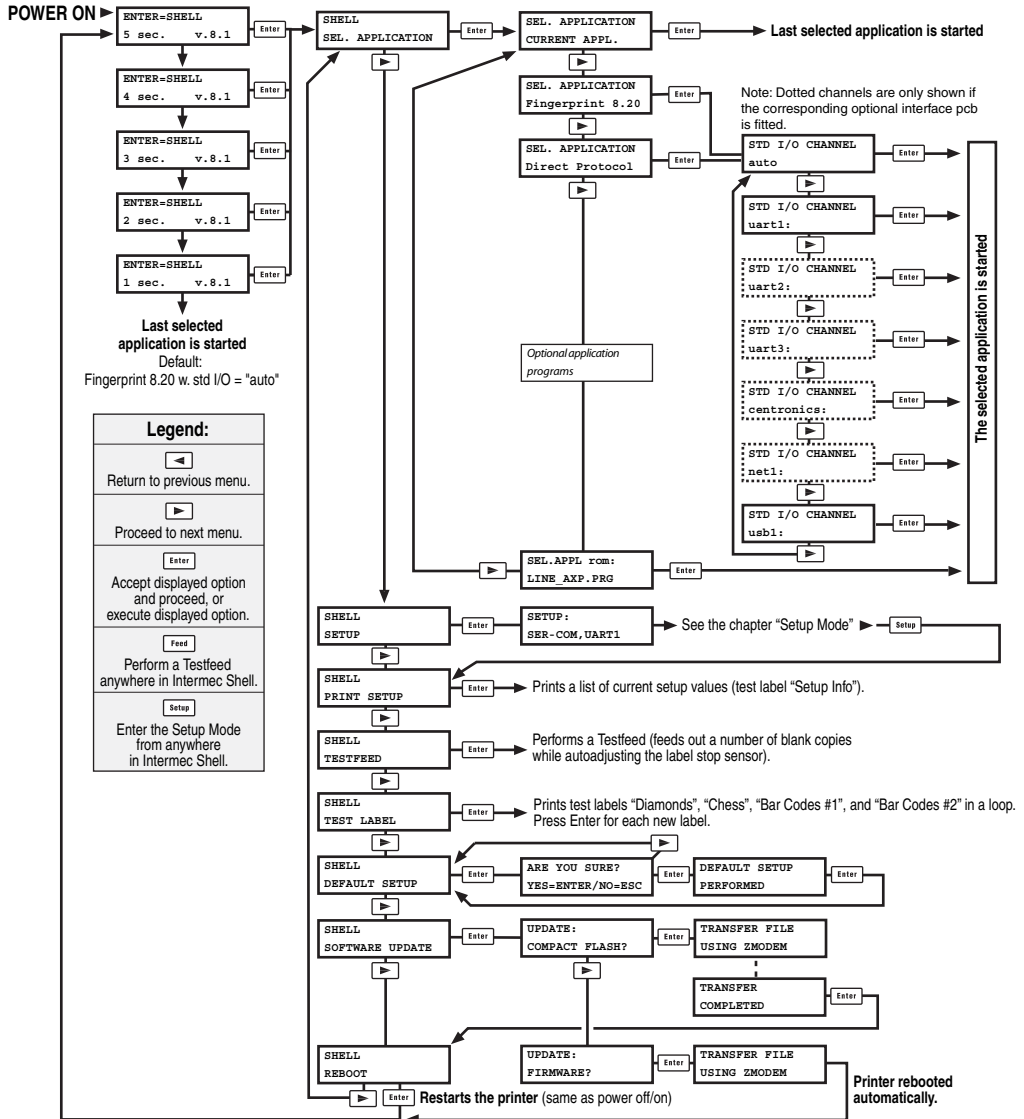

Line Analyzer

The Line Analyzer (LINE_AXP.PRG) is a program written in the Intermec Fingerprint programming language and is intended to help solving possible communication problems. As the name implies, the Line Analyzer captures all incoming characters on a specified communication channel and prints them on one or more labels.

Printable characters are printed in black-on-white, whereas control characters and space characters (ASCII 000–032 dec) are printed in white-on-black.

While the printer is receiving data, the “Ready” control lamp blinks. There is a 0.5 second time-out. That is, if no more characters have been received after 0.5 second, the program considers the transmission terminated and prints out a label.

As long as a continuous string of characters is being received, the program wraps the lines until the label is full and then starts to print another label. At the bottom of each label, the following information is printed:

- Page number
- Number of characters printed on the label
- Total number of characters received so far

The Line Analyzer is displayed as the option “LINE_AXP.PRG” under the “SEL. APPLICATION” menu. After the Line Analyzer has been selected and the printer has started up again, the printer feeds out two labels and the following menu is displayed:

```
Line Analyzer
Sel.port(1-6) 1
```

Enter the desired communication port using the numeric keys on the printer’s keyboard:

- 1 = "uart1:"
- 2 = "uart2:"
- 3 = "uart3:"
- 4 = "centronics:"

5 = "net1:"

6 = "usb1:"

If the printer is not fitted with the specified port, an error message appears in the display and you can select another port:

Line Analyzer

Error: 56

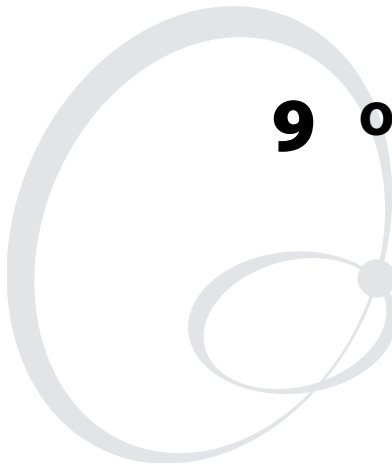
A decorative graphic consisting of two overlapping circles. The larger circle is on the left and the smaller one is on the right, partially overlapping the larger one. The circles are light gray and have a thin, slightly irregular border.

9 Options

This chapter describes the options available for the EasyCoder PF2i printer. The options can be factory installed, field-installed by an authorized service technician, or in some cases installed by the operator.

Introduction

The EasyCoder PF2i printer provides a high degree of flexibility because it has a modular design. By adding options to the basic printer, the EasyCoder PF2i printer can be adapted for a variety of applications. Most options can easily be installed by the operator, however a few should be installed by an authorized service technician or are only available as factory-installed options.

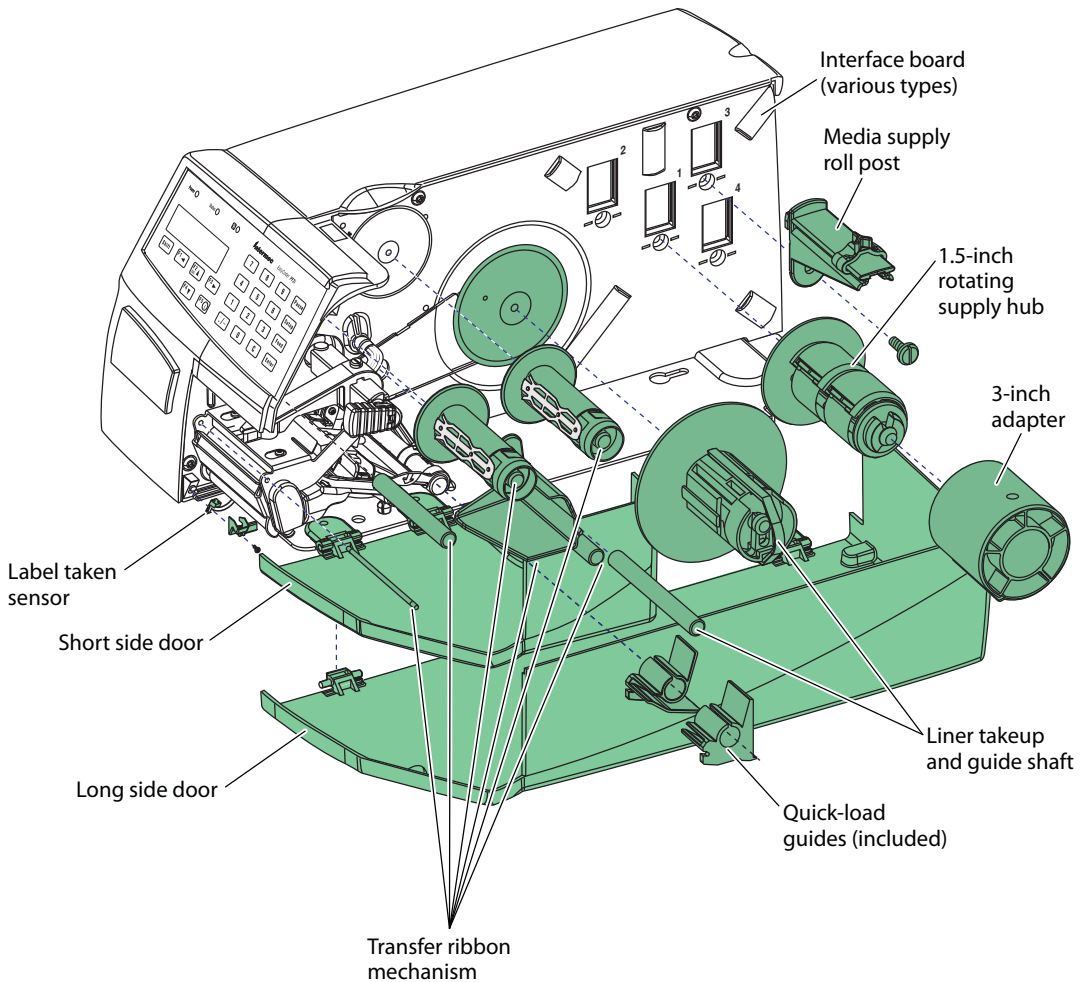

Transfer Mechanism

The thermal transfer mechanism is only available as a factory-installed option. It allows the use of both direct thermal and thermal transfer supplies.

Side Doors

The EasyCoder PF2i printer comes with either a short side door, which only covers the print mechanism or with a long side door, which encloses the entire media compartment. The long side door has a slot for external media supply. The long side door is generally illustrated throughout this manual, but pictures of the short side door can be found at the start of this chapter and in [“Media Load” on page 25](#).

Integral Liner Takeup Unit

The integral liner takeup unit is an optional device for peel-off (self-strip) operation, which means the labels are separated from a liner (backing paper) after printing and the liner is wound up on an internal hub. The unit also includes a guide shaft. Peel-off cannot be combined with quick-load guides, see below.

Media Supply Hub

The rotating media supply hub is designed to fit media roll cores with an internal diameter of 38-40 mm (1.5 inch). The hub can be fitted in the same positions as the supply roll post, see [“Media Compartment” on page 8](#). Being factory installed, the position of the media supply hub is not intended to be changed by the operator.

3-Inch Adapter

The 3-inch/76 mm adapter is used with a rotating media supply hub and makes it possible to use media rolls with 3-inch/76 mm inner diameter cores. The adapter is pressed onto the hub and secured by a screw. Not used with a media supply roll post.

Label Taken Sensor

The Label Taken Sensor (LTS) is a photoelectric sensor that enables the printer’s firmware to detect if the latest printed label, ticket, tag, etc. has been removed before printing another copy.

The LTS can be enabled or disabled by means of the instructions LTS&ON and LTS&OFF respectively in Intermec Fingerprint and the Intermec Direct Protocol.

Real Time Clock

The Real Time Clock circuit (RTC) relieves the operator or the host from having to set the clock/calendar using the Intermec Fingerprint instructions DATE\$ and TIME\$ after each power up. The RTC has its own backup battery backup that will last 10 years or more.

CompactFlash Protection Plate

The protection plate encloses an inserted CompactFlash card and makes it more difficult to steal. See “[Memory Card](#)” on page 20 for illustration.

Interface Boards

A number of interface boards are available for use with the EasyCoder PF2i printer. The interface boards are either factory-fitted or can easily be fitted by an authorized service technician.

The EasyCoder PF2i printer can accommodate one EasyLAN interface board plus one other interface board.

EasyLAN boards:

- EasyLAN Ethernet interface
- EasyLAN Wireless interface

Other communication boards:

- Parallel Interface Board (IEEE 1284)
- Double Serial Interface Board
- Serial/Industrial Interface Board

A decorative graphic consisting of two overlapping circles. The larger circle is on the left and the smaller one is on the right, partially overlapping the larger one. Both circles are light gray.

10 Troubleshooting

This chapter describes how the Intermec Ready-To-Work Indicators work. It also lists various possible cases of inferior printout quality, describes possible causes, and suggests remedies.

Intermec Ready-To-Work Indicator

The readiness of the printer, individually or as a part of a solution, is indicated by the blue Intermec Ready-To-Work Indicator (IRI).

If the IRI blinks or is switched off, the printer is not ready. Further information can be obtained in the display window by pressing the **F5/i** key. In case of several errors or similar conditions occurring simultaneously, only the most significant error is displayed. Once this error has been cleared, next remaining error is displayed.

The printer will also return error messages to the host, provided there is a working two-way communication. Refer to the *Intermec Fingerprint v8.xx, Command Reference Manual*.

Provided the printer is connected to a network, all conditions that prevents printing are reported to the Easy ADC Console. The Easy ADC Console is a PC-based software which allows a supervisor to monitor all connected devices that have an Intermec Ready-To-Work Indicator, including handheld computers, access points, and printers.

Display Messages and LED Indications

Error/Event	IRI	Error No.	Comment
Operational	On	0	No Error
Out of paper	Blink	1005	
Next label not found	Blink	1031	
Label not taken	Blink		
Out of transfer ribbon	Blink	1027	
Head lifted	Blink	1022	
Cutter does not respond	Blink	1059	
Cutter error1	Blink	1701	
Cutter error2	Blink	1702	
Cutter error3	Blink	1703	
Cutter open	Blink	1704	
LSS too high	Blink	1007	

Display Messages and LED Indications (continued)

Error/Event	IRI	Error No.	Comment
LSS too low	Blink	1008	
Testfeed not done	Blink	1606	
Pause Mode entered	Blink		
Setup Mode entered	Blink		Including interactive setup from Fingerprint/ Direct Protocol
IP link error	Blink		See note 1, 2, and 3
IP configuration error	Blink		See note 1, 3, and 4
Generic DP error	Blink		See note 5
Press any key to continue	Blink		See note 6
Application load error	Blink		See note 7
IRI blink by application	Blink		Set by Fingerprint instruction SYSHEALTH
IRI off by application	Off		Set by Fingerprint instruction SYSHEALTH
Application break	Off		See note 8
Printhead not found	Off		
Rebooted	Off		
Initializing	Off		Set at startup until operational
Printer crash	Off		See note 3 and 9
Printer turned off	Off		
Maintenance	Off		Set when upgrading
Power supply Over temperature	Off	1718	

Note 1: This is only applicable for printers equipped with an EasyLAN interface.

Note 2: A printer that is equipped with an EasyLAN interface, but is not connected to a network, will have a blinking IRI. To avoid this, the user can set “IP SELECTION” to “MANUAL” and “IP ADDRESS” to “0.0.0.0”. This will indicate that the user does not regard the lack of network connection as an error.

Note 3: No trap can be sent when this error/event occurs.

Note 4: This error indicates that the printer has not received an IP address. It is only applicable for printers with IP SELECTION set to DHCP and/or BOOTP.

Note 5: In the Direct Protocol, the user can enable error handling for specific errors using the ERROR statement. When errors added to the built-in error handling occur, this event will be set. The text included in the snmp trap is the standard text corresponding to the error.

Note 6: If an error occurs in the Fingerprint immediate mode, for example “out of paper” when the print key is pressed, this event will be set.

Note 7: If an application is started but does not execute, the IRI will blink. This will occur for example if there is a syntax error in the loaded program file. This is useful when a printer has an AUTOEXEC.BAT file (startup file) that is supposed to run automatically.

Note 8: When execution is stopped with user break (SHIFT + PAUSE) or due to a run-time error, the IRI shall be off. It will be set to on if the user changes mode to Direct Protocol or runs an application. If, however, the application program handles the user break (ON BREAK) or the runtime error (ON ERROR GOTO), the IRI will not be affected. In this case, it is up to the application to set the status.



Note 9: At most, but not all, printer crashes, the console is reset. This will make the IRI go off.

Troubleshooting List



List of Problems and Remedies

Symptom	Possible Cause	Remedy	Refer to
Overall weak printout	Wrong media grade	Change parameter	“Setup Parameters” on page 52, “Intermec Supplies” on page 151
	Contrast value too low	Change parameter	“Setup Parameters” on page 52
	Printhead pressure too low	Adjust	“Printhead Pressure Adjustment” on page 121
	Worn printhead	Replace printhead	“Printhead Replacement” on page 109
	Wrong printhead voltage	Replace CPU board	☎ Call Service
Printout weaker on one side	Uneven printhead pressure	Adjust arm alignment	“Printhead Pressure Adjustment” on page 121
Weak spots	Foreign particles on media	Clean or replace	“Media Load” on page 25, “Ribbon Load” on page 42
	Media/ribbon don't match	Change to matching media	“Media” on page 56
	Poor media or ribbon quality	Select a better brand of media/ribbon	“Intermec Supplies” on page 151
	Worn printhead	Replace printhead	“Printhead Replacement” on page 109

List of Problems and Remedies (continued)

Symptom	Possible Cause	Remedy	Refer to
	Worn platen roller	Check/replace	 Call Service
Overall dark printout	Wrong media grade	Change parameter	“Media” on page 56,
	Contrast value too high	Change parameter	“Setup Parameters” on page 52
	Printhead pressure too high	Adjust	“Printhead Pressure Adjustment” on page 121
	Wrong printhead voltage	Replace CPU board	 Call Service
Excessive bleeding	Wrong media grade	Change parameter	“Setup Parameters” on page 52, “Intermec Supplies” on page 151
	Contrast value too high	Change parameter	“Setup Parameters” on page 52
	Printhead pressure too high	Adjust	“Printhead Pressure Adjustment” on page 121
	Faulty energy control	Replace CPU board	 Call Service
Dark lines along media path	Foreign objects on printhead	Clean printhead	“Printhead Cleaning” on page 102
White vertical lines	Printhead dirty	Clean printhead	“Printhead Cleaning” on page 102
	Missing printhead dots	Replace printhead	“Printhead Replacement” on page 109

List of Problems and Remedies (continued)

Symptom	Possible Cause	Remedy	Refer to
Large part of dot line missing	Failing printhead	Replace printhead	“Printhead Replacement” on page 109
	Failing strobe signal	Check CPU-board	 Call Service
	Wrong X-Start or Width parameter	Change parameter	“Setting Up the Printer” on page 49
Printout missing along inner edge	Bad media alignment	Adjust	“Media Load” on page 25
	Small core & supply post in upper pos.	Move post to lower pos.	“Media Supply Positions” on page 10
	X-Start parameter value too low	Increase	“Setup Parameters” on page 52
Transfer ribbon breaks	Ribbon not fitted correctly	Reload ribbon	“Ribbon Load” on page 42
	Wrong media grade	Change parameter, then clean printhead	“Setup Parameters” on page 52, “Printhead Cleaning” on page 102
	Bad energy control	Adjust	 Call service
Transfer ribbon wrinkles	Faulty ribbon break shaft adjustment	Adjust	“Ribbon Break Shaft Adjustment” on page 1231
	Incorrect edge guide adjustment	Adjust	“Media Load” on page 25
	Too strong printhead pressure	Adjust	“Printhead Pressure Adjustment” on page 121

List of Problems and Remedies (continued)

Symptom	Possible Cause	Remedy	Refer to
No thermal transfer printout	Ink-coated side does not face media	Reload ribbon	“Ribbon Load” on page 42
Media feed not working properly	Change media characteristics	Press the Print button	“Media Load” on page 25
	Wrong label rest dots parameter	Check/change	“Setup Parameters” on page 52
	Wrong Media Type parameter	Check/change	“Media” on page 56
	Wrong LSS position	Check/change	“Media” on page 56
	Dirty sensors	Clean media guides	“Cleaning the Media Guides” on page 107
	Faulty sensors	Replace	 Call Service
Compressed text or bar code	Too high speed for large media roll	Lower print speed	“Media” on page 56

11 Maintenance

This chapter describes how the operator can maintain the printer. Regular maintenance is important for the printout quality and for the life of the printhead. The chapter covers the following topics:

- Printhead Cleaning
- External Cleaning
- Cleaning the Media Guides
- Printhead Replacement
- Media Jams



Follow ESD
Procedures

When cleaning or replacing the printhead, take ample precautions to avoid electrostatic discharges.

Printhead Cleaning

Cleaning the printhead on a regular basis is important for the life of the printhead and for the printout quality. You should clean the printhead each time you replace the media. This section describes how to clean the printhead using cleaning cards. If additional cleaning is required, for example removing adhesive residue from the platen roller or tear bar, use a cotton swab moistened with isopropyl alcohol.



Isopropyl alcohol [(CH₃)₂CHOH; CAS 67-63-0] is a highly flammable, moderately toxic, and mildly irritating substance.

To clean the printhead

- 1 Open the side door.

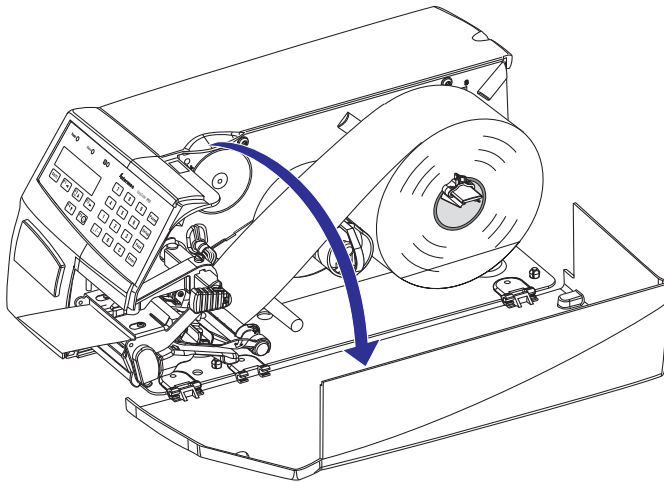

- 2 Turn the printhead lift lever clockwise to raise the printhead.

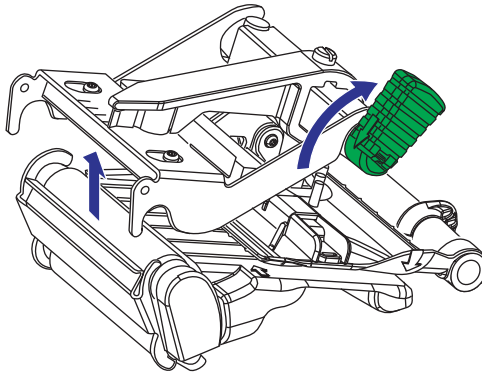

- 3 Remove any media (and ribbon).

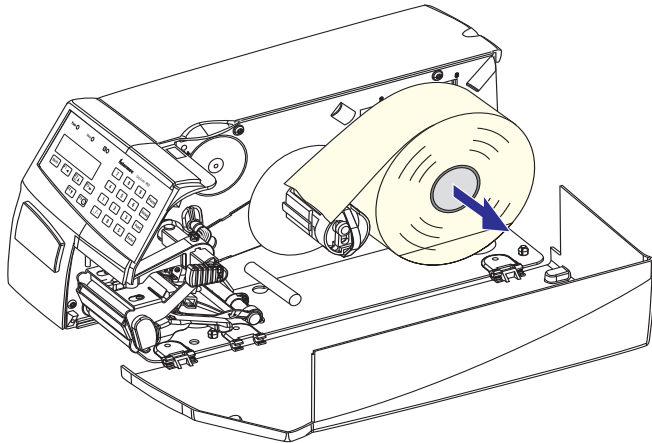

- 4 Open the cleaning card envelope and pull out the cleaning card. Read the warning test.

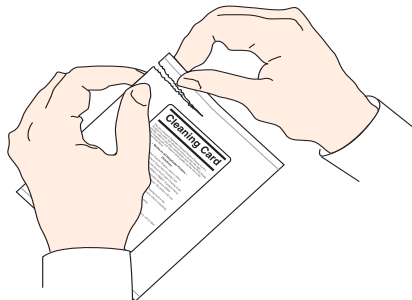

- 5 Insert most of the cleaning card under the printhead (1). Engage the printhead (2).

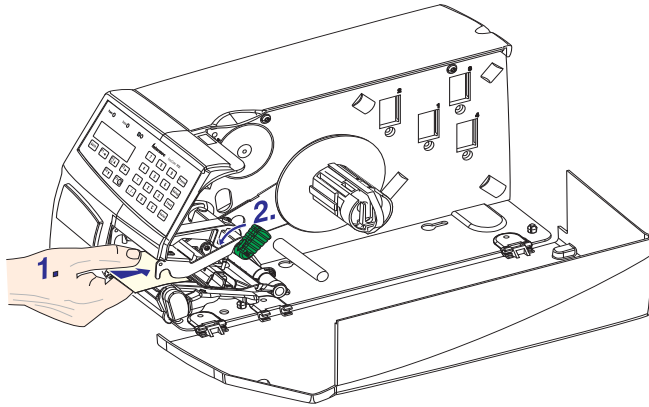

- 6 Pull out the cleaning card (1) and raise the printhead (2).

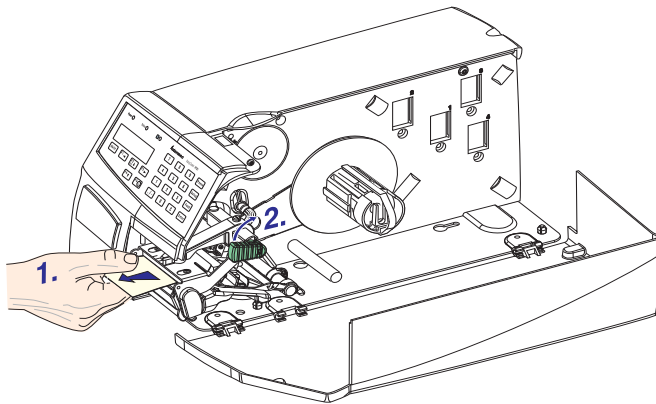

- 7 Wait for approx. 30 seconds to allow the cleaning fluid to dissolve the residue.

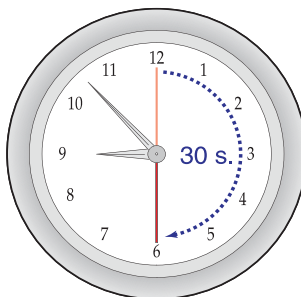

- 8** Insert most of the cleaning card under the printhead (1). Engage the printhead (2).

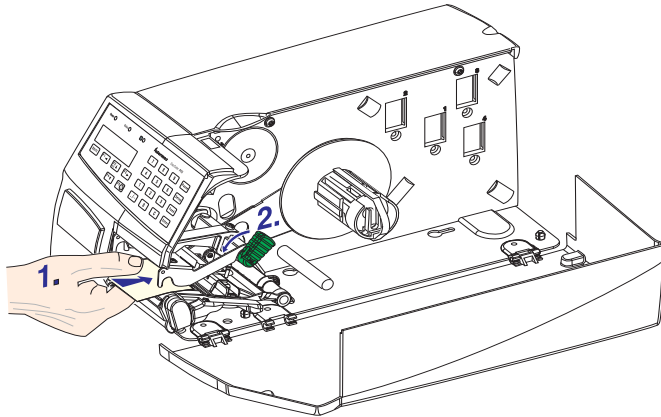

- 9** Pull out the cleaning card. If necessary, repeat the process with a fresh cleaning card.

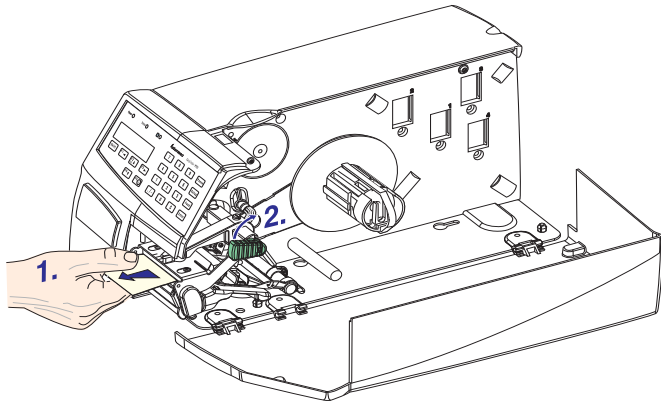

- 10** Allow the cleaned parts to dry before loading any media (and ribbon).

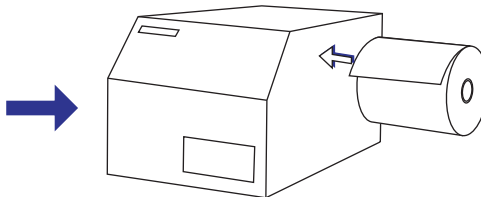

External Cleaning

To clean the exterior

- 1 Always remove the power cord before cleaning!

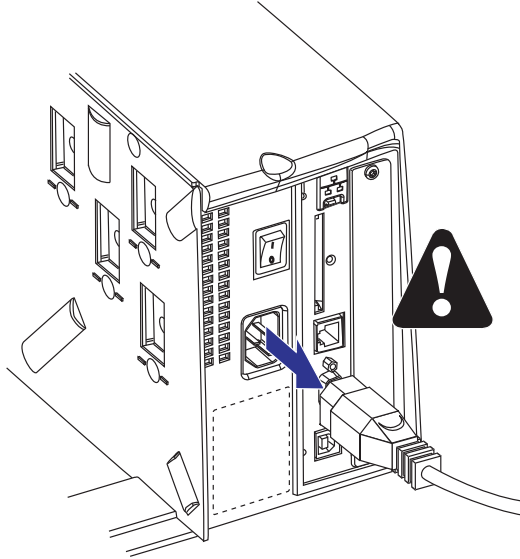

- 2 Wipe external surfaces with a soft cloth slightly moistened with water or a mild detergent.

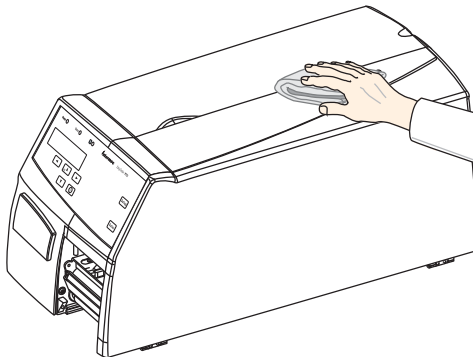
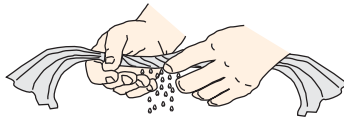

- 3 Never spray the printer. Protect it from water when cleaning the premises.

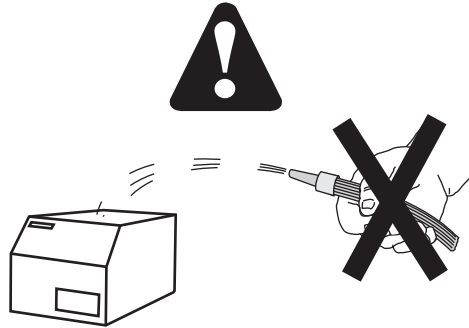

- 4 Never use any sharp tools for removing stuck labels. The printhead and rollers are delicate.

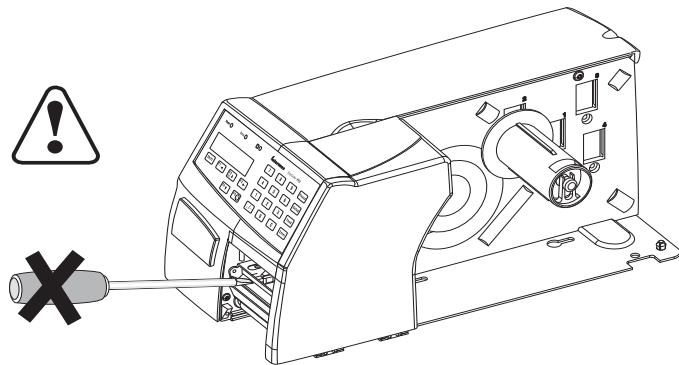

Cleaning the Media Guides

Both parts of the label stop sensor, which controls the media feed, are covered by plastic guides. The guides are transparent to allow the light to pass between the two parts of the label stop sensor. These areas (indicated by a shade of gray in illustration #2 below) must be kept clean from dust, stuck labels, and adhesive residue.

If the printer starts to feed our labels in an unexpected way, raise the upper guide as described below and check for any object that may block the beam of light (dust, stuck labels, adhesive residue, etc.). If necessary, clean the guides using a cleaning card or a soft cloth soaked with isopropyl alcohol. Do not use any other type of chemical. Be careful not to scratch the guides.



Isopropyl alcohol [(CH₃)₂CHOH; CAS 67-63-0] is a highly flammable, moderately toxic, and mildly irritating substance.

To clean the media guides

- 1 Lift the inner part of the upper guide and pull it outwards, disengaging it from the lower guide. Take care not to damage the cable.

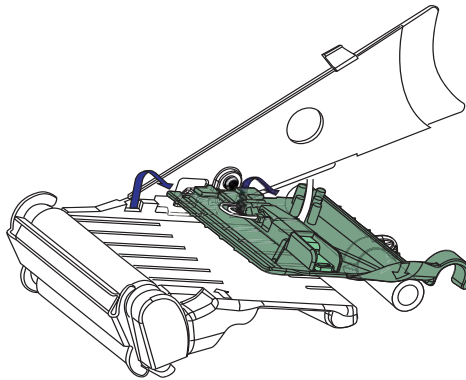

- 2 Tilt the upper guide upwards and clean the areas marked with gray. After cleaning, reassemble in reverse order.

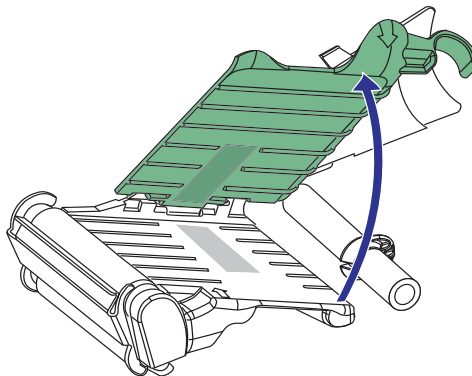

Printhead Replacement

The printhead is subject to wear both from the direct thermal media (or ribbon) and from the rapid heating and cooling process during printing. Thus, the printhead will require periodic replacement.

Time between printhead replacements depends on the print images, the type of direct thermal media (or ribbon) in use, the amount of energy to the printhead, the print speed, the ambient temperature, and several other factors.



While replacing the printhead, the power must be off. The firmware will not detect the new printhead resistance until the printer has been restarted.

To replace the printhead

- 1 Open the side door.

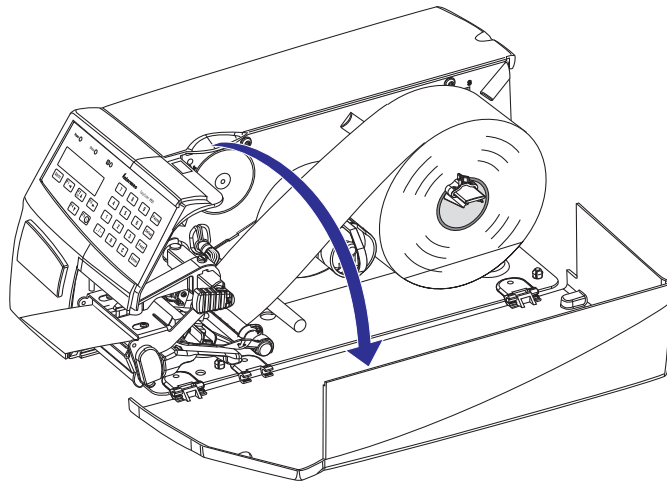

- 2 Turn the printhead lift lever clockwise to raise the printhead.

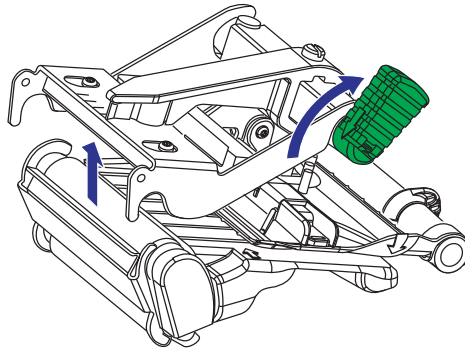

- 3 Remove the media (and ribbon).

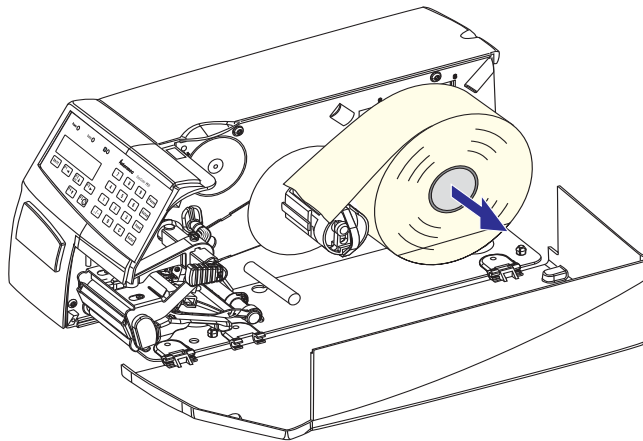

- 4 Pull the printhead bracket away from the magnet in the pressure arm.

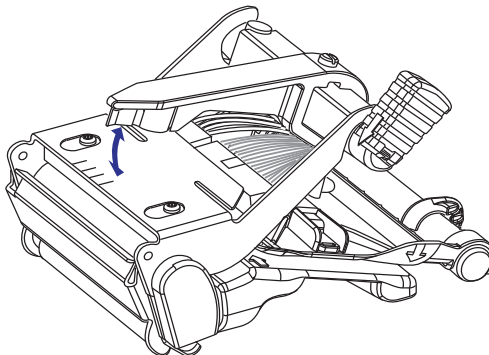

- 5 Disconnect the printhead bracket from the print mechanism as indicated by the arrows and pull out the printhead as far as the cables allow.

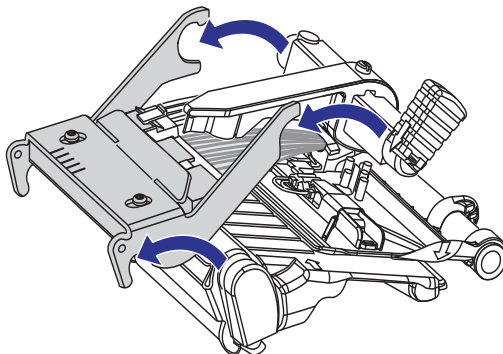

- 6 Disconnect the cables from the printhead. Note the snap-lock on the inner connector. Pull at the connectors - not at the cables!

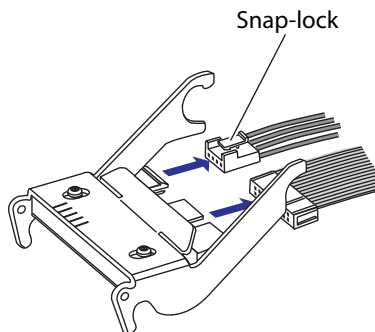

- 7 Connect the two cables to replacement printhead.

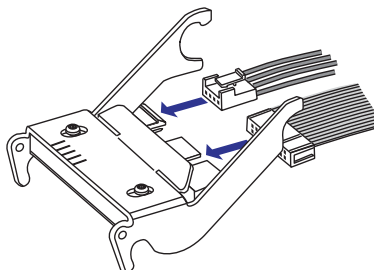

- 8** Put back the printhead in reverse order and check that the printhead cables run freely.

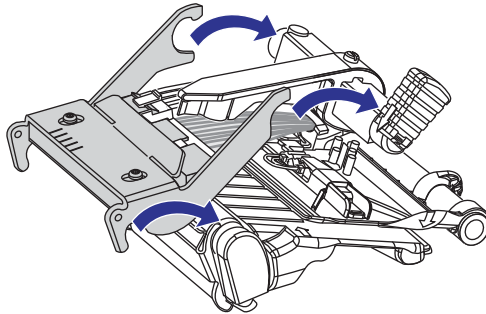

- 9** Turn the printhead lift lever counterclockwise, so the magnet engages the printhead bracket.

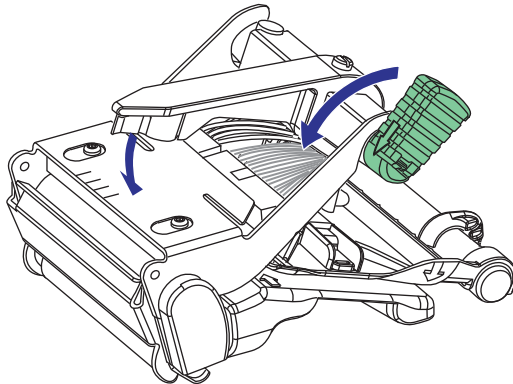

- 10** Load a new supply of media (and ribbon), as described earlier in this manual.

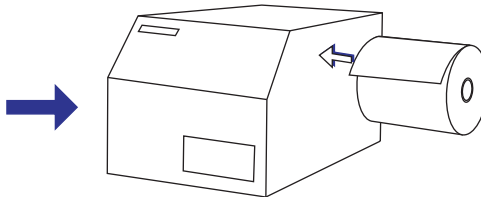

Media Jams

Should a media jam occur in the print mechanism, proceed this way to clear it:

- Always switch off the power before starting to clear the jammed media.
- Raise the printhead and pull out the media.
- If the media has been wound up or has stuck on the platen roller, carefully remove it by hand without using any sharp tools that can damage the delicate platen roller or printhead. Avoid rotating the platen roller.



Caution

If you must pull away the media by force causing the platen roller to rotate, it is very important that the power has been off for a minute or more. If not, the electronics can be damaged beyond repair.

- Cut off any damaged or wrinkled part.
- Check if there is any adhesive somewhere in the print mechanism, clean using a cleaning card or cotton swab soaked in isopropyl alcohol.



Warning

Isopropyl alcohol [(CH₃)₂CHOH; CAS 67-63-0] is a highly flammable, moderately toxic, and mildly irritating substance.

- Reload the media as described in [“Media Load” on page 25](#).
- Switch on the power.
- Readjust the media feed by pressing the Feed key.



12 Adjustments

This chapter describes how the operator can adjust the printer. The chapter covers the following topics:

- Narrow Media Adjustment
- Label Stop Sensor Position Adjustment
- Printhead Pressure Adjustment
- Ribbon Break Shaft Adjustment
- Quick-Load Guides Installation
- Label Taken Sensor Adjustment

Narrow Media Adjustment

The printer is factory-adjusted for full-size media width. When using media less than full width, it is recommended that you adjust the position of the pressure arm, so it becomes centered with the media. Thereby, an even pressure across the media is obtained.

A poorly adjusted pressure arm may be detected by a weaker printout on either side of the media path.

To adjust the pressure arm, proceed as follows:

- 1 Loosen the straight-slot screw that holds the pressure arm.
- 2 Move the arm inwards or outwards until the arrow on the tip of the arm becomes centered with the media.

While moving the arm, push at the part where the screw is situated, not at the tip. If the arm is hard to move, lift the printhead and pull the printhead bracket free from the magnet in the arm.

- 3 After having centered the arm, lock it by tightening the screw.

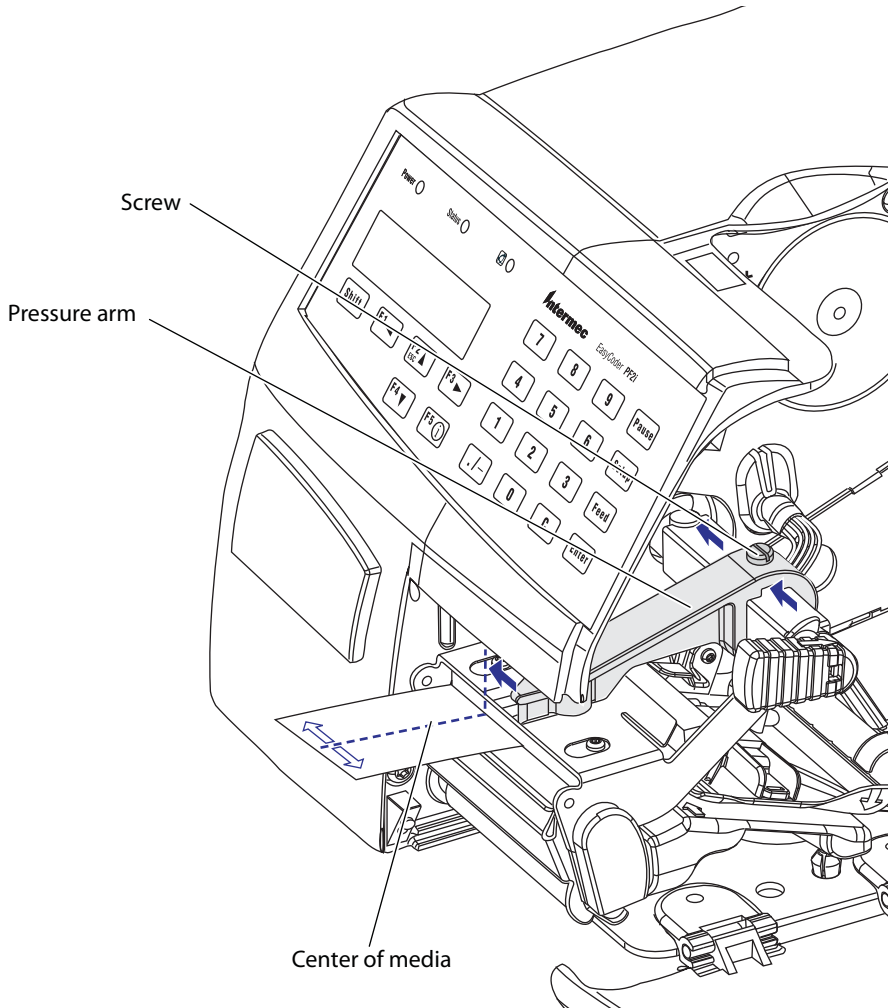

Label Stop Sensor (LSS) Position Adjustment

The label stop/black mark sensor (LSS) is a photoelectric sensor that controls the printer's media feed by detecting gaps between labels, or slots or black marks in continuous stock, depending on the printer's setup in regard of media type (see “[Label Stop Sensor \(LSS\) Position Adjustment](#)” on page 118). An obvious prerequisite is that the LSS must be aligned with the gaps, slots, or black marks. If using irregularly shaped labels, align the LSS with the front tips of the labels.

The LSS can be moved laterally between five fixed positions. There is one part of the sensor on top of the upper media guide and another part underneath the lower guide. These must be adjusted individually to the same position. Using a small screwdriver, push them inwards as far as they go and then pull them out—one at the time—while counting the clicks from the snap-locks.

The various detection points of the sensor in relation to the inner edge of the media are as follows:

LSS Detection points

One click out	3 mm	0.118 inches
Two clicks out	8 mm	0.315 inches
Three clicks out	12 mm	0.472 inches
Four clicks out	16 mm	0.639 inches
Five clicks out	20 mm	0.787 inches

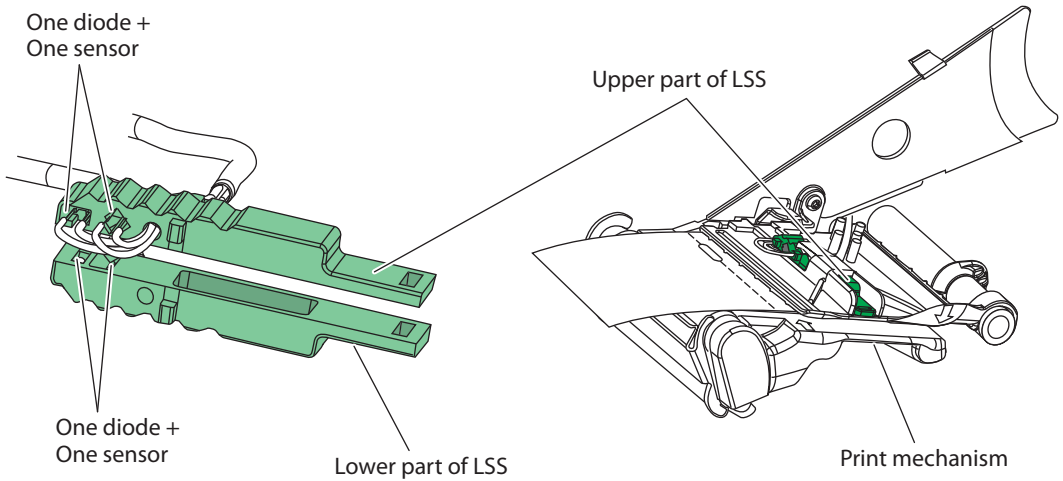

In the Print Defines part of the Setup Mode, you have two ways to test the label stop sensor if you have a detection problem; LSS Auto and LSS Manual.

The menu only provides indications from the label stop sensor unit. The testing menu can determine if the sensor unit is not physically in position, is blocked by dust or stuck labels, or is defective in some way. Furthermore, this is an aid if media has detection complication.



Note: There is no way to adjust the LSS-function; the menu only indicate values from the LSS obtained by performing a TESTFEED operation.

LSS Auto is the quick and normal way to determine if the label stop sensor works properly and is able to detect gaps, slots, or black marks.

LSS Manual shows the actual setting provided by the latest TESTFEED operation. It is also possible to try other settings. LSS Manual is primarily intended for service and is not described in this manual.

LSS Auto

- Check that the printer is set up for the type of media loaded in your printer (Setup Mode/Media/Media type/LABELS

(with GAPS);TICKET (with MARK), TICKET (with GAPS), FIX LENGTH STRIP; or VAR LENGTH STRIP.

- Perform a TESTFEED by simultaneously pressing the **Shift** and **Feed** keys on the printer's keyboard.
- Make sure that there is a label—not a gap or mark—at the LSS.
- Check that the media is routed as close to the center section as the guides allow.
- Enter the Setup Mode (see “[Setup Mode](#)” on page 67) and go to Setup Mode/Print Defines/LSS Test/LSS Auto.
- The menu should look like this with the cursor placed in the center:



LSS Auto

■

- **Gap or slot detection:**

Lift the printhead and pull out the media slowly. When the LSS detects a gap or a detection slot, the cursor moves to the right.

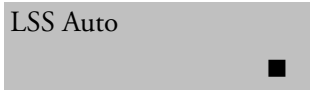

LSS Auto

■

- **Black mark detection:**

Lift the printhead and pull out the media slowly. When the LSS detects a black, the cursor moves to the left.

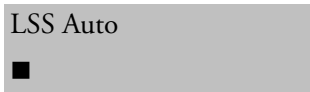

LSS Auto

■

- It is possible to refresh the centered cursor position by pressing the **▼/F4** key.
- If the cursor behaves as described above, the LSS is working and is properly aligned with the gaps, slots, or black marks.

- If the cursor does not react on a gap, slot, or black mark, check this:
 - Is the LSS laterally aligned with the slots or black marks?
 - Are both the upper and lower part of the LSS aligned with each other?
 - Is the transfer ribbon properly loaded so it does not interfere with the LSS? (See **“Ribbon Load” on page 42**)
 - Are the LSS guides clean and free from stuck labels or other objects that will interfere with the light that goes from one part of the LSS to the other? If not, clean as described in **“Cleaning the Media Guides” on page 107**.
 - Does the media have some kind of preprint that can disturb the detection?
 - Is there too little difference between the black marks and the surrounding areas?
 - Does the liner have too little transparency?
 - Does the LSS work with another type of media? (Remember to change the Media Type setup and perform a new TESTFEED.)

Printhead Pressure Adjustment

The pressure of the thermal printhead against the direct thermal media is factory-adjusted. However, the use of thicker or thinner media than normal could require the printhead pressure to be readjusted.

Using a straight-slot screwdriver, turn the adjustment screw clockwise for more pressure (+) or counterclockwise for less pressure (-). Print a few labels, preferably test labels (see **“Setting Up the Printer” on page 49**) and check the printout. Increased pressure generally gives a darker printout and vice versa. Repeat until the desired result is obtained.

To return to the factory setting, tighten the screw (+) as far as it goes and then loosen it (-) six full turns.



Do not use a higher printhead pressure than necessary, because it may increase the wear of the printhead and shorten its life.

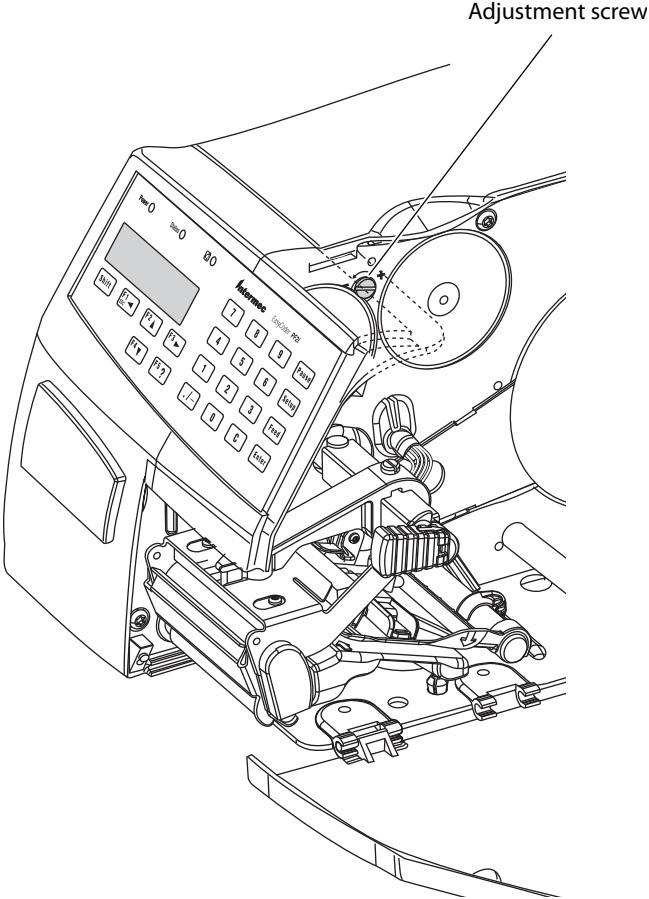

Ribbon Break Shaft Adjustment

If ribbon wrinkling occurs, you may need to adjust the alignment of the front ribbon break shaft so that it runs parallel to the printhead and the ribbon supply and rewind hubs. The adjustment is done using a straight-slot screw that is located immediately behind the front ribbon break shaft.

- If the ribbon tends to slide outwards, turn the screw carefully clockwise (fw) to move the outer end of the break shaft forward.
- If the ribbon tends to slide inwards, turn the screw carefully counterclockwise (bw) to move the outer end of the break shaft backward.



Before readjusting the break shaft, make sure that there is no other cause for the wrinkling of the ribbon. (See “[Troubleshooting List](#)” on page 97)

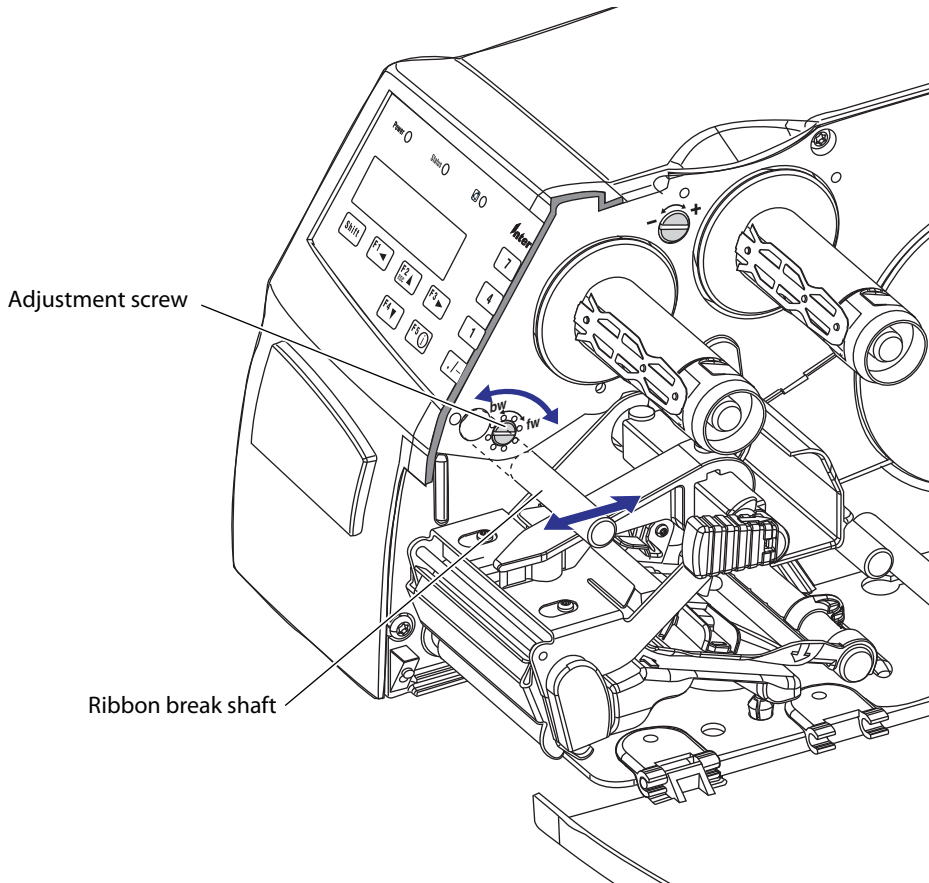

Installing the Quick-Load Guides

The quick-load guides may, depending on model, be factory-installed or be enclosed in the box for optional installation by the user. They replace the standard edge guide.

The quick-load guides facilitate media load from behind the print mechanism and help guiding the media when using an external supply. Quick-load guides cannot be used for peel-off operation.

The standard ring-shaped edge guide is used when you want to load the media from the side rather than from behind and is necessary for peel-off operation.

The quick-load guides can be used with media that is 40-60 mm (1.57-2.36 inches) wide. The inner guide should be fitted flush to the center section, whereas the outer of the guide is adjustable for various media widths. Refer to **“Tear-Off With Quick-Load (Straight-Through)” on page 30** for loading instructions.

To install the Quick-Load Guides

- 1 Lift up the upper media guide and pull out the green edge guide (save it for later use).

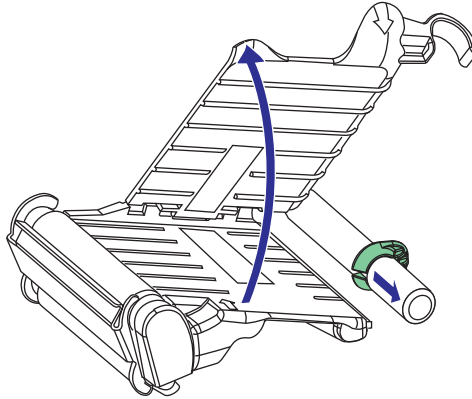

- 2 Press the quick-load guides onto the shaft as illustrated, making sure that the notches fit the rail at the rear of the lower media guide.

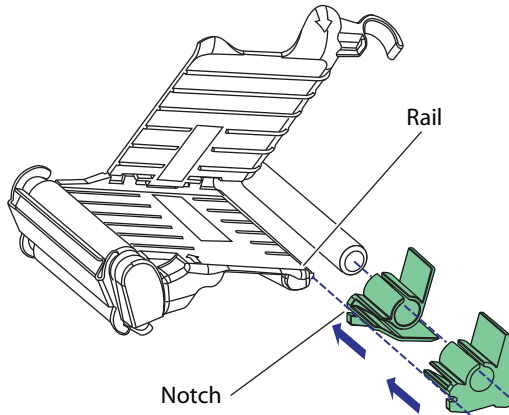

Label Taken Sensor (LTS) Adjustment

The sensitivity of the LTS may need to be adjusted according to ambient light conditions and reflective characteristics of the back side of the media. This is done in the Setup Mode (Print Defs/LTS), see “[Setup Mode](#)” on page 67. You can also check that the LTS works properly.

The LTS setup options are only displayed if an optional label taken sensor is installed in the printer.

LTS Adjust

Press **Enter**. A label is fed out. Remove the label and press **Enter** again. A menu shows the sensitivity automatically selected by the firmware and the range, in which the LTS will work. Press **Enter** again and you will proceed to the LTS Test menu.

LTS Test

Press **Enter**. A label is fed out. Remove the label and a new label should be fed out automatically. Repeat until you are sure the LTS works properly. Then press **Enter** to stop and exit.

LTS Value

Press **Enter**. You can enter a new value in the range indicated in the LTS Adjust menu. Min/max values are in the range 0 to 10.

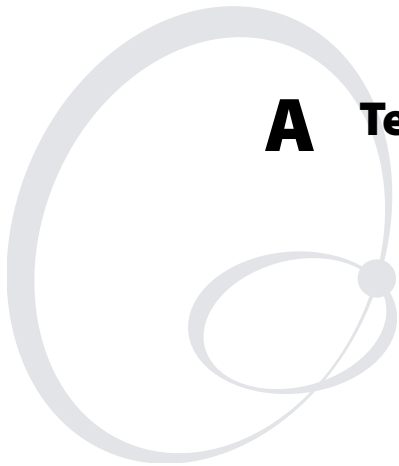

A Technical Specifications

This appendix lists the technical data for the printer. Please note that Intermec reserves the right to change without prior notice and that this information does not represent a commitment on the part of Intermec.

Technical Data

Printing		
Print Technique	Direct Thermal (Thermal Transfer as option)	
Printhead Resolution	8 dots/mm (203.2 dpi)	
Print Speed (variable)	100 to 200 mm/sec. (≈ 4 to 8 in./sec.)	
Print Width	56 mm (2.2 inches)	=448 dots
Print Length (max)	32767 dots = 409.5 cm (161.25 inches) ¹	
Media Width (min/max)	25 to 60 mm (1 to 2.36 inches)	Standard edge guide
Media Width (min/max)	40 to 60 mm (1.57 to 2.36 inches)	Quick-load guides
Media Roll Diameter (max)	213 mm (8.38 inches)	
Media Roll Core Diameter	38 to 40 mm (1.5 inches) or 76 mm (3 inches)	
Ribbon Width (min/max)	25 to 60 mm (1 to 2.36 inches)	
Ribbon Roll Diameter (outer)	64 mm (2.56 inches) equivalent to 240-300 m (787-985 ft) of ribbon	Depending on ribbon thickness
Ribbon Roll Core Diameter (inner)	25.4 mm (1.00 inches)	
Print directions	4	

1. The max. print length is also restricted by the amount of free SDRAM memory.

Modes of Operation		
Tear-Off (Straight-through)	Yes	
Peel-Off (Self-strip)	Optional	With liner takeup unit

Firmware		
Operating System	Intermec Fingerprint v8.20	
Smooth Fronts	TrueDoc and TrueType fonts	
Built-in scalable fonts (std)	15	Unicode fonts ¹
Startup Program (std)	Intermec Shell v8.1	
Built-in bar codes (std)	53	

1. Latin, Greek, and Cyrillic fonts according to Unicode standard are included.

Physical Measures		
Dimensions (W x L x H)	194 x 397 x 178 mm (7.64 x 15.63 x 7.00 inches)	With long side door
Weight (excluding media)	approx. 5.5 kg (12 pounds)	
Ambient Operating Temperature	+5°C to +40°C (+41°F to +104°F)	
Humidity	20 to 80% non-condensing	

Electronics		
Microprocessor	32 bit RISC	
On-board Flash SIMMs	2 sockets for 4MB or 8MB each	Std. 1 x 4MB
On-board SDRAM	1 socket for 8MB or 16MB	Std. 8MB

Power Supply	
AC Voltage	90 to 265 VAC, 45 to 65 Hz
PFC Regulation	IEC 61000-3-2
Power Consumption	Standby 15W; Peak 300W

Appendix A — Technical Specifications

Sensors		
Gap/Mark/Out of Media	Yes	5 fixed positions
Printhead Lifted	Yes	
Ribbon End	Thermal transfer	model only

Controls		
Control Lamps	3	
Display	2 x 16 character LCD	Background light
Keyboard	22 keys membrane-switch	
Print button	1	
Beeper	Yes	

Data Interfaces		
Serial	1 x RS-232 + 1 x USB	
Bar Code Wand	Yes	
Connection for Optional Interface Boards	1 + 1	1 for EasyLAN, 1 for other board
Memory Card Adapter	1	CompactFlash cards

Accessories and Options		
Transfer Ribbon Mechanism	Option	
Integral Self-strip Unit with Liner Takeup	Option	For peel-off operation
Rotating Media Supply Hub	Option	Replaces supply post
3-inch Adapter	Option	
Short Side Door	Option ¹	
Long Side Door	Option ¹	
Label Taken Sensor	Option	
Real Time Clock	Option	10+ years life
RS-232 Cable	Option	
Parallel Interface Cable	Option	

Accessories and Options		
Parallel Interface Board	Option	IEEE 1284
Double Serial Interface Board	Option	
Serial/Industrial Interface Board	Option	
EasyLAN Ethernet Interface	Option	
EasyLAN Wireless Interface	Option	
CompactFlash Card Protection Plate	Option	
CompactFlash Cards	Option	8MB-1GB

1. Depending on model, the printer may be delivered with either a long or a short side door.

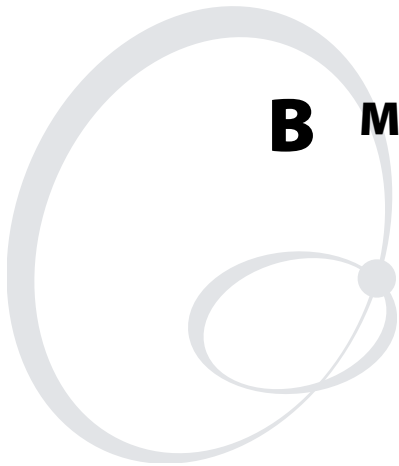

B Media Specifications

This appendix specifies the physical measures for various types of media.

Media Roll Size

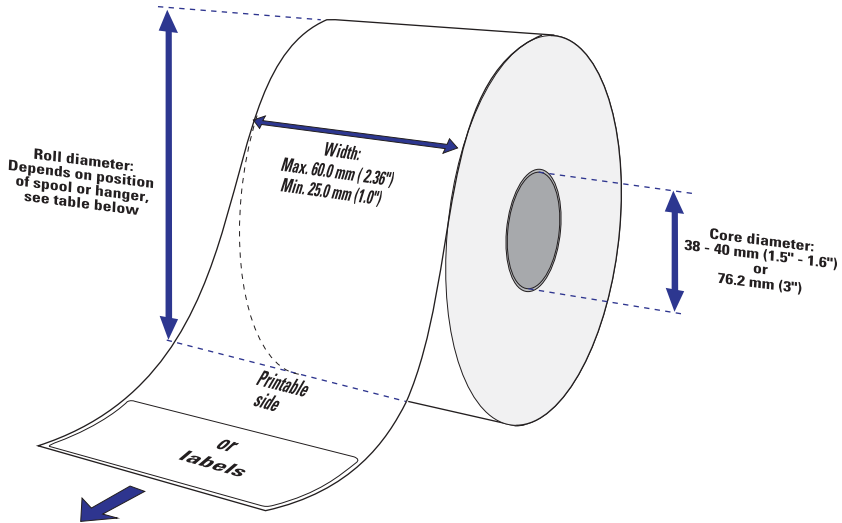

Core

Diameters: 38-40 mm (1.5 inches) or 76.2 mm (3 inches)

Width: Must not protrude outside the Media



The media must be wound up on the core in such a way that the printer can pull the end free.

Roll

Max Diameter:

- Position 1: 152 mm (6.00 inches)
- Position 2: 203 mm (8.00 inches)
- Position 3: 213 mm (8.38 inches)

Max width: 60 mm (2.36 inches)

Min. width (standard): 25 mm (2.00 inches)

Min. width (quick-load): 40 mm (1.57 inches)

The maximum recommended media thickness is 175 μ m (0.007 inches). Thicker media may be used, but print quality will be reduced. The stiffness is also important and must be balanced against thickness to maintain print quality.

Media rolls to be loaded inside the printer should be wound with the printable side facing outwards.

The media supply must not be exposed to dust, sand, grit, etc. Any hard particles, however small, can damage the printhead.

Media

Non-Adhesive Strip

$\Leftarrow a \Rightarrow$ Media Width

Maximum: 60.0 mm (2.36 inches)

Minimum (standard): 25.0 mm (1.00 inches)

Minimum (quick-load): 40.0 mm (1.57 inches)

Media Type Setup

- Fix length strip
- Var length strip



Self-Adhesive Strip

⇐ a ⇒ Media Width (including liner)

Maximum: 60.0 mm (2.36 inches)

Minimum (standard): 25.0 mm (1.00 inches)

Minimum (quick-load): 40.0 mm (1.57 inches)

⇐ b ⇒ Linear

The liner must not extend more than a total of 1.6 mm (0.06 inches) outside the face material and should protrude equally on both sides.

⇐ c ⇒ Media Width (excluding liner)

Maximum: 58.4 mm (2.30 inches)

Minimum: 23.8 mm (0.94 inches)

Media Type Setup

- Fix length strip
- Var length strip



Self-Adhesive Labels

⇐ a ⇒ **Media Width (including liner)**

Maximum: 60.0 mm (2.36 inches)

Minimum (standard): 25.0 mm (1.00 inches)

Minimum (quick-load): 40.0 mm (1.57 inches)

⇐ b ⇒ **Liner**

The backing paper must not extend more than a total of 1.6 mm (0.06 inches) outside the labels and should protrude equally on both side. Recommended minimum transparency: 40% (DIN 53147).

⇐ c ⇒ **Label Width (excluding liner)**

Maximum: 58.4 mm (2.30 inches)

Minimum: 23.8 mm (0.94 inches)

⇐ d ⇒ **Label Length**

Maximum: depends on SDRAM size

Minimum: 8.0 mm (0.32 inches)

Under ideal circumstances, a minimum label length of 4 mm (0.16 inches) could be used. It requires the sum of the label length (d) and the label gap (e) to be larger than 7 mm (0.28 inches), that batch printing is used, and that no pull back of the media is performed. Intermec does not guarantee that such short labels will work, but it is up to the user to test this in his unique application.

⇐ e ⇒ **Label Gap**

Maximum: 21.3 mm (0.83 inches)

Recommended: 3.0 mm (0.12 inches)

Minimum: 1.2 mm (0.05 inches)

The Label Stop Sensor must be able to detect the extreme front edges of the labels. It can be moved between 5 fixed positions (see [“Label Stop Sensor \(LSS\) Position Adjustment” on page 118](#)).

Media Type Setup

- Label (with gaps)

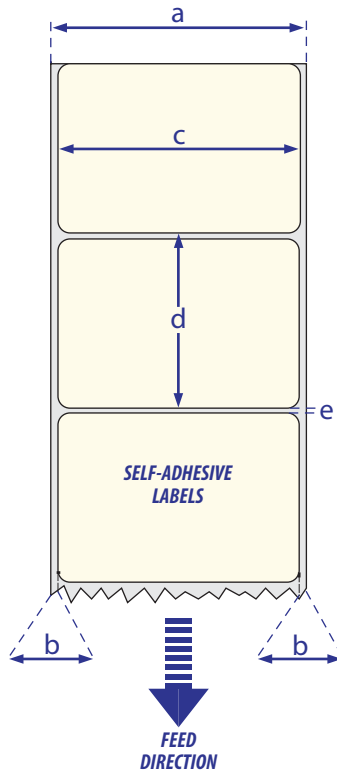

Tickets with Gaps

⇐ **a** ⇒ **Media Width**

Maximum: 60.0 mm (2.36 inches)

Minimum (standard): 25.0 mm (1.00 inches)

Minimum (quick-load): 40.0 mm (1.57 inches)

⇐ **b** ⇒ **Copy Length**

Max. length between slots: depends on SDRAM size

Min. length between slots: 8.0 mm (0.32 inches)

Under ideal circumstances, a minimum ticket length of 4 mm (0.16 inches) could be used. It requires the sum of the copy length (b) and the detection slit height (e) to be larger than 7 mm (0.28 inches), that batch printing is used, and that no pull back of the media is performed. Intermec does not guarantee that such short tickets will work, but it is up to the user to test this in his unique application.

⇐ c ⇒ LSS Detection Position

Five fixed positions, see “[Label Stop Sensor \(LSS\) Position Adjustment](#)” on page 118.

⇐ d ⇒ Detection Slit Length

The length of the detection slit (excluding corner radii) must be minimum 2.5 mm (0.10 inches) on either side of the LSS detection position (e).

⇐ e ⇒ Detection Slit Height

Maximum: 21.3 mm (0.83 inches)

Recommended: 1.6 mm (0.06 inches)

Minimum: 1.2 mm (0.05 inches)

Media Type Setup

- Ticket (with gaps)



Note: Do not allow any perforation to break the edge of the media as this may cause the media to split and jam the printer.

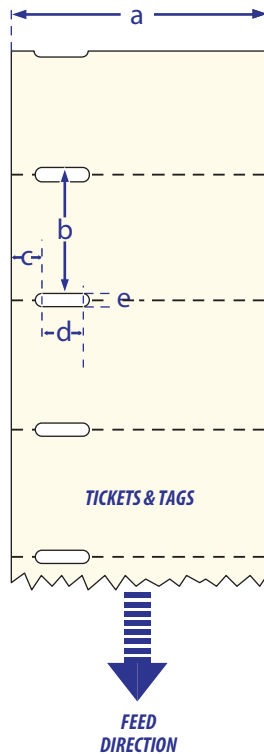

Tickets with Black Mark

⇐ a ⇒ **Media Width**

Maximum: 60.0 mm (2.36 inches)

Minimum (standard): 25.0 mm (1.00 inches)

Minimum (quick-load): 40.0 mm (1.57 inches)

⇐ b ⇒ **Copy Length**

Minimum: 20.0 mm (0.8 inches)

Maximum: depends on SDRAM size

⇐ c ⇒ **LSS Detection Position**

Five fixed positions, see [“Label Stop Sensor \(LSS\) Position Adjustment” on page 118.](#)

⇐ d ⇒ **Black Mark Width**

The detectable width of the black mark should be at least 5.0 mm (0.2 inches) on either side of the LSS detection point.

← e ⇒ Black Mark Length

Maximum: 21.3 mm (0.83 inches)

Common: 12.5 mm (0.5 inches)

Minimum: 5.0 mm (0.2 inches)

← f ⇒ Black Mark Y-Position

It is recommended that you place the black mark as close to the front edge of the ticket as possible and control the media feed, so the tickets can be properly torn off.

Media Type Setup

- Ticket (with mark)



Note: Preprint that may interfere with the detection of the black mark should be avoided. However, the Intermec Fingerprint statement LBLCOND allows the sensor to be temporarily disabled during a specified amount of media feed in order to avoid unintentional detection, see Intermec Fingerprint manuals.



Note: The black mark should be non-reflective carbon black on a whitish background. Do not allow any perforations to break the edge of the media as this may cause the media to split and jam the printer.

Appendix B — Media Specifications

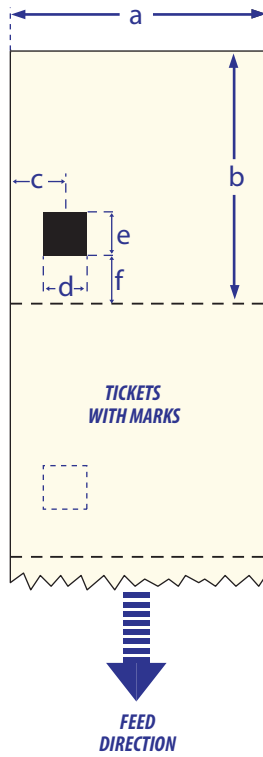

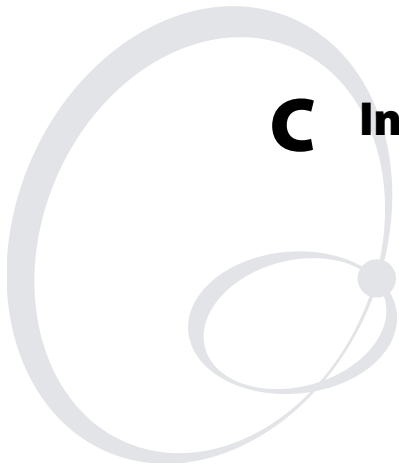

C Interfaces

This appendix describes the interface connectors found on the printer's rear plate. It covers the following topics:

- RS-232 Interface
- USB Interface
- Bar Code Wand Interface
- Optional Interface Boards

RS-232 Interface

Protocol

Default setup:

Baud rate: 9600

Character length: 8 bits

Parity: None

Stop bits: 1

RTS/CTS: Disabled

ENQ/ACK: Disabled

XON/XOFF: Disabled (both ways)

New Line: CR/LF

To change the RS-232 interface settings, see [“Setting Up the Printer” on page 49](#).

Signals on Printer’s Serial Port “uart1:”

DB-9	Signal	Meaning
1		External =5V DC*
2	TXD	Transmit data
3	RXD	Receive data
4	DSR	Data set ready
5	GND	Ground
6	DTR	Data terminal ready
7	CTS	Clear to send
8	RTS	Request to send
9	–	Not used

* The external +5V is limited to 500 mA and is automatically switched off at overload.

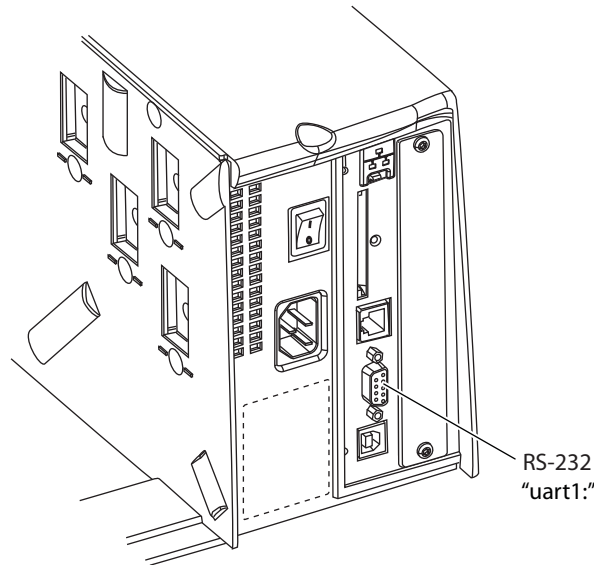

Interface Cable

Computer end: Depends on computer model

Printer end: DB-9 pin plug

USB Interface

This printer supports USB v1.1 (also called USB 2.0 full speed). To use the USB interface for printing from a PC, you need a special Intermec USB printer driver installed in your PC.

The printer is a so called “self-powered device.” We recommend that you only connect one printer to each USB port on the host, either directly or via a hub. Other devices, like a keyboard and a mouse, can be connected to the same hub. If you need to connect more than one Intermec USB printer to a host, you should use different USB ports.

Using a USB Class A/B cable, connect the Class A plug to your PC or hub and the Class B plug to your printer.

The USB interface is essentially a one-way communication interface and is thus not recommended for programming. There is no communication setup for the USB port.

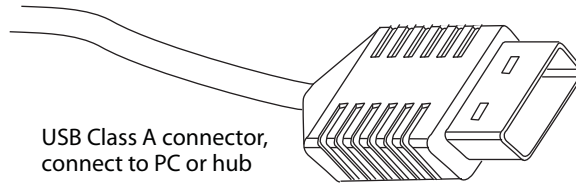

USB Class A connector,
connect to PC or hub

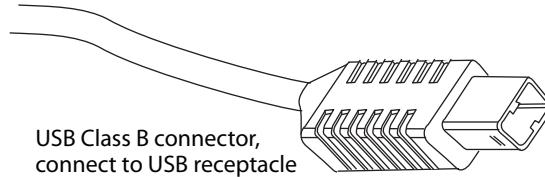

USB Class B connector,
connect to USB receptacle
on the printer's rear plate

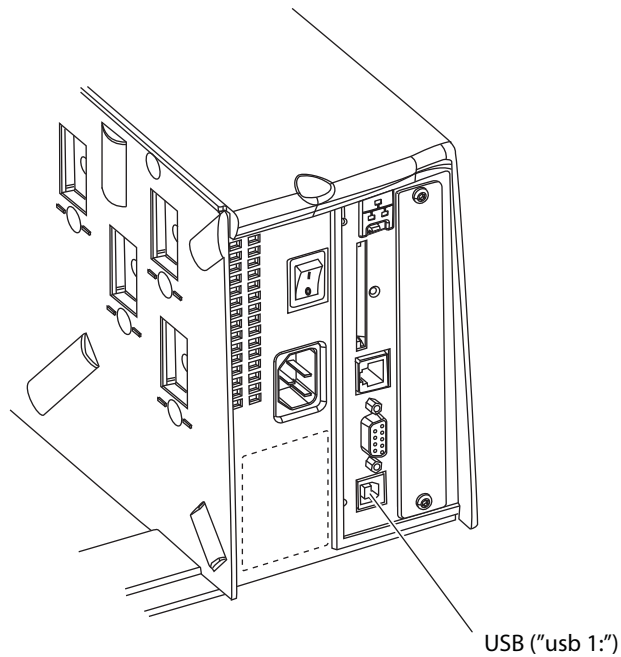

Bar Code Wand Interface

The printer has a socket on the CPU board for connecting a bar code wand or scanner. The socket is accessible through a slot in the printer's rear plate.

If a Code 128 bar code that contains the character FNC3 is read via this port, the data will be treated as a setup string and will change the printer's setup accordingly. A setup bar code may contain a single parameter or a combination of up to 3 or 4 setup parameters. Refer to the *EasySet Bar Code Wand Setup manual* (P/N 1-960560-00) for more information on how to produce setup bar codes.

The printer will acknowledge that a bar code has been successfully read by emitting a short beep signal.

If no FNC3 character is found in the bar code, the data will be stored in a buffer which could be read by specifying the "wand:" device. The buffer is small, so it is recommended to use short bar code data (max. 16 characters) and read the buffer regularly to avoid overflow.

For more demanding applications or for reading bar codes other than Code 128, choose a regular bar code scanner from Intermec's wide product range and connect it to a serial port.

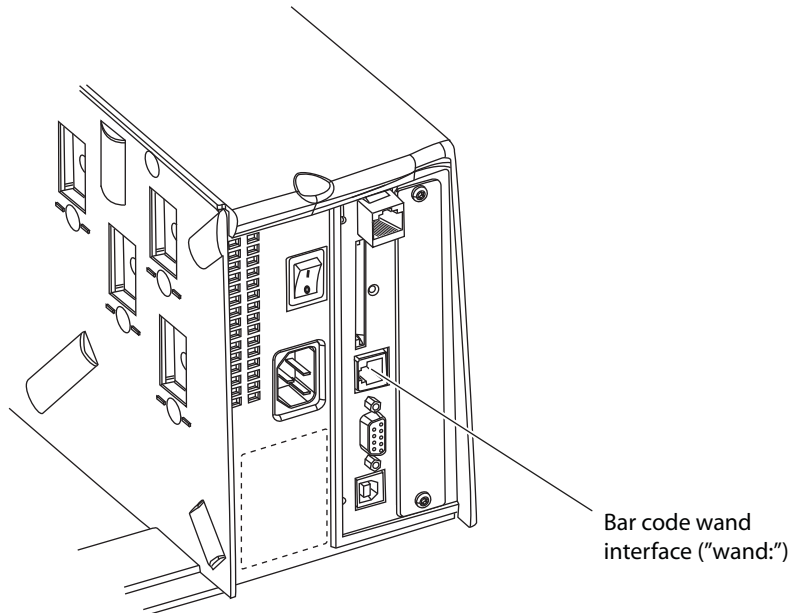

Optional Interfaces

The printer can optionally be fitted with one of the following interface boards at the right-hand side of the printer's rear plate.

Appendix C — Interfaces

- Double Serial Interface Board (device "uart2:" and "uart3:")
- Serial/Industrial Interface Board (device "uart2:")
- IEEE 1284 Parallel Interface Board (device "centronics:")

Regardless of if any Parallel Interface Board is installed, the printer can also be fitted with one of the following EasyLAN interface boards for connection to a Local Area Network (LAN):

- EasyLAN Ethernet Interface (device "net1:")
- EasyLAN Wireless Interface (device "net1:")

Double Serial Interface Board

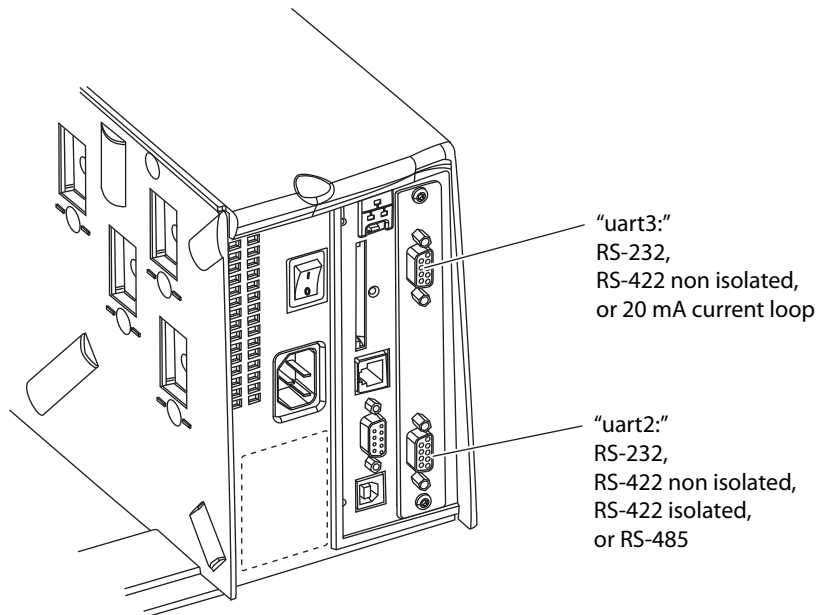

Serial/Industrial Interface Board

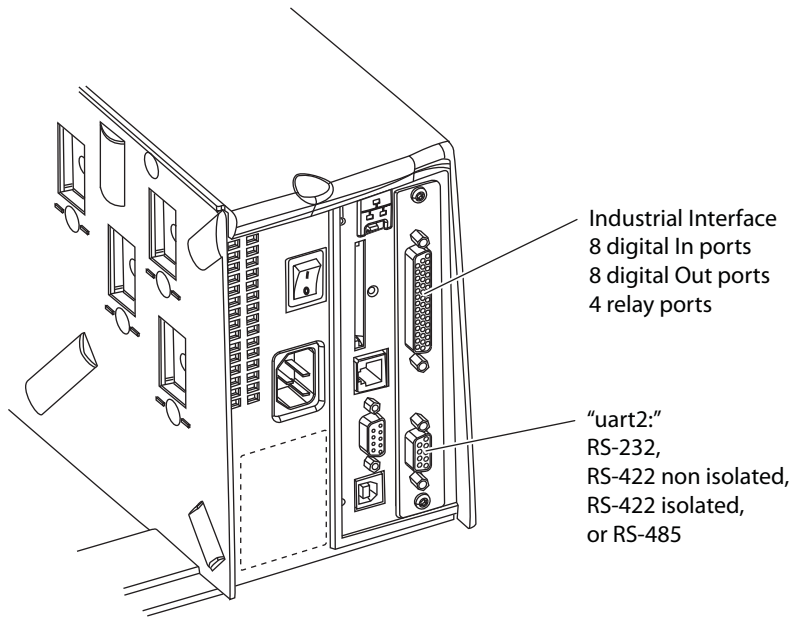

IEEE 1284 Parallel Interface Board

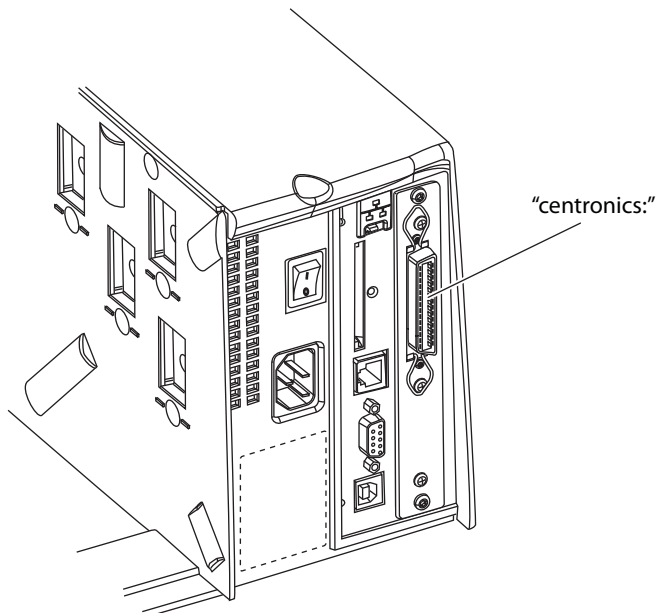

EasyLAN Ethernet Interface

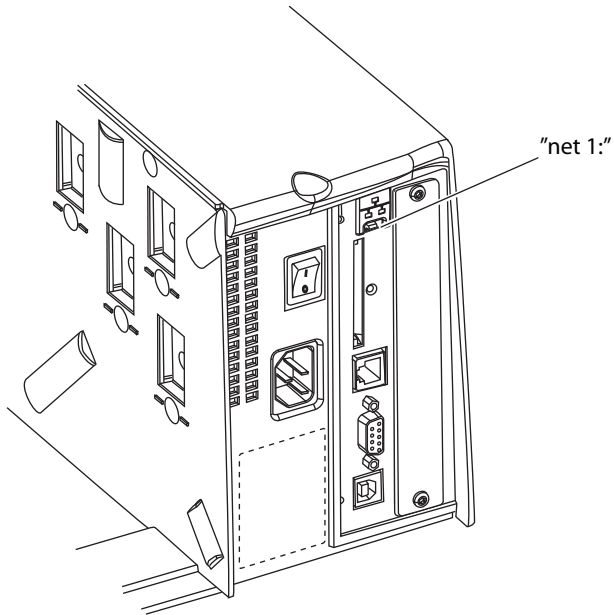

EasyLAN Wireless Interface

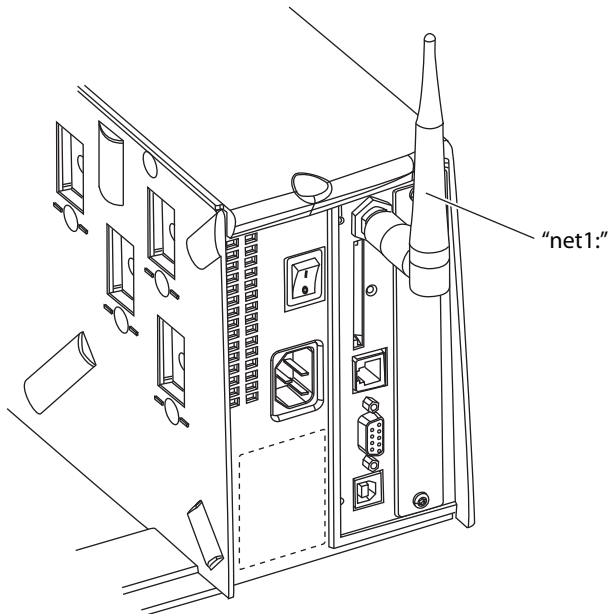

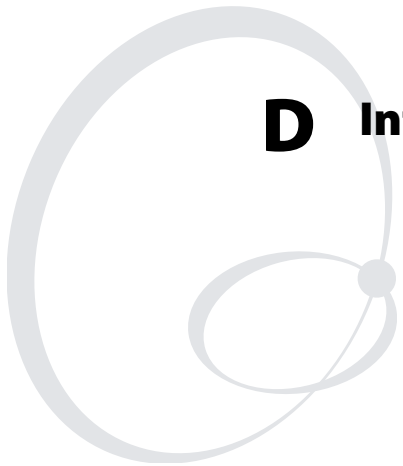

D Intermec Supplies

This appendix describes the supplies offered by Intermec for use with this printer, that is, direct thermal media, thermal transfer ribbons, and receiving face materials for thermal transfer printing.

Direct Thermal Media

Intermec offers two quality grades of direct thermal media for the Easy-Coder printers:

Premium Quality

Top-coated media with high demands on printout quality and resistance against moisture, plasticizers, and vegetable oils.

Examples:

Europe	North America
Thermal Top Board	Duratherm II
Thermal Top	Duratherm II Tag
Thermal Top High Speed	Duratherm Ltg.
	Duratherm IR

Economy Quality

Non top-coated media with less resistance to moisture, plasticizers, and vegetable oils. In all other respects, it is equal to Premium Quality. Examples:

Europe	North America
Thermal Eco	—
Thermal Eco Board	

Thermal Transfer Media

Intermec offers stock labels for thermal transfer printing in a wide range of quality grades.

Uncoated Papers

Economical high-volume printing. To be used with GP/TMX 1500 ribbons. Examples:

Europe	North America
TTR Uncoated	—

Coated Papers

Various coat-weight, smoothness, and gloss. To be used with HP/TMX 2200/2500 and GP/TMX1500 ribbons. Examples:

Europe	North America
TTR Coated	Duratran II
TTR Premium	Duratran II Tag
TTR Premium Board	Valeron Tag
TTR High Gloss White	

Polyethylene Plastics

These media have better resistance to water and many common chemicals than uncoated and coated papers. They can be use outdoors and offer good tear resistance. Most often used with HP/TMX 2200/TMX 2500 ribbons. Examples:

Europe	North America
TTR Polyethylene	Kimdura
TTR Gloss Polyethylene	Syntran

Polyesters

These media give high resistance to chemicals, heat, and mechanical abrasion with HR/TMX 3200 ribbons. Examples:

Europe	North America
TTR High Gloss Polyester	PET Gloss

Transfer Ribbons

Intermec offer three ranges of thermal transfer ribbons optimized for different purposes:

- **General Purpose (GP/TMX 1500)** transfer ribbons allow high speed printing and give a good printout, but are somewhat sensitive to smearing. They may be the best choice for uncoated and coated papers.
- **High Performance (HP/TMX 2200, TMX 2500)** transfer ribbons allow high speed printing and give a highly readable and de. ned printout on most face materials with smooth

surfaces. They have good “smear resistance” and are most suitable for intricate logotypes and images on matte-coated papers and synthetic face materials.

- **High Resistance (HR/TMX 3200)** transfer ribbons give an extremely durable printout, which is resistant to most chemical agents and high temperatures. However, such transfer ribbons set high demands on the receiving face material, which must be very smooth, such as polyesters.

The use of HR/TMX 3200 ribbons requires the print speed and the energy supplied by the printhead to be controlled with great accuracy according to the receiving face material. Custom-made setup options adapted for special applications can also be created. Consult your Intermec distributor.



Note: Intermec thermal transfer ribbons are engineered specifically for the EasyCoder printheads.

Bar Code Directions

In the tables on the pages that follow, different maximum print speeds may be recommended depending on the direction of possible bar codes in the printout. Generally, ladder style bar codes are more demanding and may require a lower print speed, especially in connection with a large media roll and/or negative start adjust values (see **“Print Speed” on page 64**). The illustration below shows how the two type of bar code directions relate to the media feed direction.

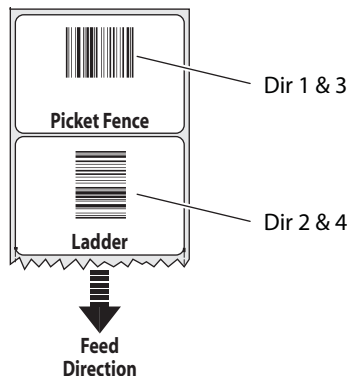

Recommended Paper Type Settings (Europe)

Direct Thermal Printing

Type/Speed	Name	Label Constant	Label Factor	Max Rec. Dir 1&3 ²	Print Speed ¹ Dir 2&4 ³
Top Coated	Thermal Top Board ⁴	110	50	100	100
Standard	Thermal Top	95	50	200	150
Non Top Coated	Thermal Eco	95	50	200	200
Standard	Thermal Eco Board ⁴	80	50	200	200
Top Coated/High	Thermal Top Coated	95	50	200	200

Thermal Transfer Printing

Type/Speed	Name	Ribbon Constant	Ribbon Factor	Label Offset	Max Rec. Dir 1&3 ²	Print Speed ¹ Dir 2&4 ³
GP02	TTR Uncoated	70	25	0	150	150
	TTR Coated	75	25	0	200	200
	TTR Premium	60	25	0	150	150
HP07	TTR Coated	100	25	0	200	200
	TTR Premium	80	25	0	200	150
	TTR Premium Board ⁴	100	25	0	150	150
	TTR Polyethylene	80	25	0	200	150
HP05	TTR Gloss Polyethylene	95	25	0	200	200
	TTR Coated	100	25	0	200	150
	TTR Premium	75	25	0	200	150
	TTR Premium Board ⁴	95	25	0	200	150
	TTR High Gloss White	80	25	0	150	150
	TTR Polyethylene	70	25	0	150	150
	TTR Gloss Polyethylene	80	25	0	200	200

Thermal Transfer Printing (continued)

Type/Speed	Name	Ribbon Constant	Ribbon Factor	Label Offset	Max Rec. Dir 1&3 ²	Print Speed ¹ Dir 2&4 ³
HR03	TTR High Gloss Polyester	90	30	0	200	200

1. Exceeding the recommended print speed may cause the printhead to wear out prematurely. If the ambient temperature is lower than =15C (+59F), decrease print speed by 50 mm/sec.
2. Applies to printing of text, lines, boxes, images, and picket fence bar codes.
3. Applies to ladder bar codes.
4. Requires high printhead pressure (See “[Printhead Pressure Adjustment](#)” on page 121).

Recommended Paper Type Settings (North America)

Direct Thermal Printing

Type/Speed	Name	Label Constant	Label Factor	Max Rec. Dir 1&3 ²	Print Speed ¹ Dir 2&4 ³
Top Coated	Duratherm II	110	50	200	200
Standard	Duratherm II Tag ⁴	110	50	200	150
Top Coated	Duratherm Lightning	90	50	200	200
High	Duratherm IR	100	50	200	200

Thermal Transfer Printing

Type/Speed	Name	Ribbon Constant	Ribbon Factor	Label Offset	Max Rec. Dir 1&3 ²	Print Speed ¹ Dir 2&4 ³
TMX 1500	Duratran II	60	25	0	200	200
	Syntran	55	25	0	200	200
	Kimdura	70	25	0	200	200
	Valeron Tag	85	25	0	200	200
	Duratran II Tag	75	25	0	200	200
TMX 2200	Duratran II	65	25	0	200	200
	Kimdura	80	25	0	200	200

Thermal Transfer Printing (continued)

Type/Speed	Name	Ribbon Constant	Ribbon Factor	Label Offset	Max Rec. Dir 1&3 ²	Print Speed ¹ Dir 2&4 ³
	Valeron Tag	90	25	0	200	200
	Duratran II Tag	80	25	0	200	200
TMX 2500	Duratran II	75	25	0	200	200
	Kimdura	90	25	0	200	200
	Valeron Tag	100	25	0	200	200
	Duratran II Tag	85	25	0	200	200
TMX 3200	Polyester	95	25	0	200	200

1. Exceeding the recommended print speed may cause the printhead to wear out prematurely. If the ambient temperature is lower than =15C (+59F), decrease print speed by 50 mm/sec.
2. Applies to printing of text, lines, boxes, images, and picket fence bar codes.
3. Applies to ladder bar codes.
4. Requires high printhead pressure (See [“Printhead Pressure Adjustment”](#) on page 121).



Intermec Technologies Corporation

Corporate Headquarters
6001 36th Avenue West
Everett, WA 98203
U.S.A.

tel +425.348.2600

fax +425.355.9551

www.intermec.com

EasyCoder PF2i Bar Code Label Printer User's Guide (Fingerprint Version)



P/N 934-033-001